

1650 McReynolds Avenue, N.W.
Grand Rapids, Michigan 49504-2043
Phone: 616-363-4416 Fax: 616-363-0380
www.bulmanproducts.com

R370-RKD 8 ROLL HORIZONTAL RACK ASSEMBLY INSTRUCTIONS

TOOLS REQUIRED: Adjustable wrench, pliers and/or socket wrenches and
Slotted screw driver

1. The unit is shipped in three separate cartons. One carton contains two T-shaped uprights, one support bar, casters, all assembly hardware and this instruction sheet. The remaining two cartons each contain four 36" cutters, each with a wood dowel.
2. Begin assembly by fastening the two T-shaped uprights together with support bar, using four ¼" x 2" bolts, nuts and washers. (See Page 2, Figure 1.) Tighten securely.
3. Begin by fastening 2 cutters in the bottom position as shown in figure 3. First fasten the top cross bars and then the bottom cross bars. (See Figures 2 & 3). **(Be sure cutters are opened up by grasping both bottom crossbars and pulling apart until the unit locks open.)** Begin from bottom as shown in Figures 2 & 3, working up to top of unit. Be sure to install cutters with each blade opening at top of cutter.
4. After all eight cutters are installed and tightened securely; fasten casters to base as shown in Figure 3.

Assembly is now complete.

5. To load paper, pull paper cutting blade upward until it reaches locking position. Insert wood dowel through paper roll, and place roll into dowel holders. Paper should unroll from top of roll if installed properly. Then push blade against paper roll.

ASSEMBLY HARDWARE

PART NUMBER

4 – ½" Nuts (For Casters)	378
4 – ¼" x 2" Bolts	67070
4 – ¼" Keps Hex Nuts	11860
4 – ¼" Flat Washers	1040
16 - #10 x 1 ¾" Bolts	379
16 - #10 Flat Washers	382
16 - #10 Keps Hex Nuts	3800



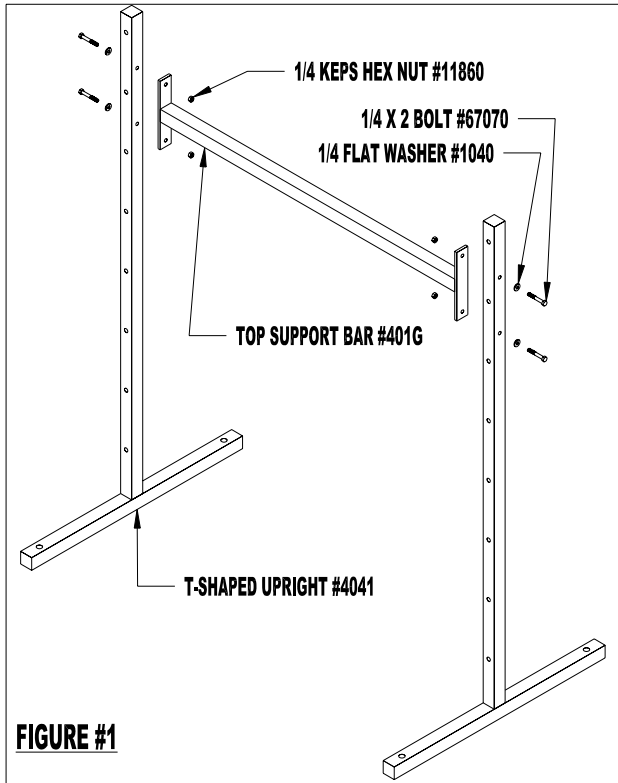

FIGURE #1

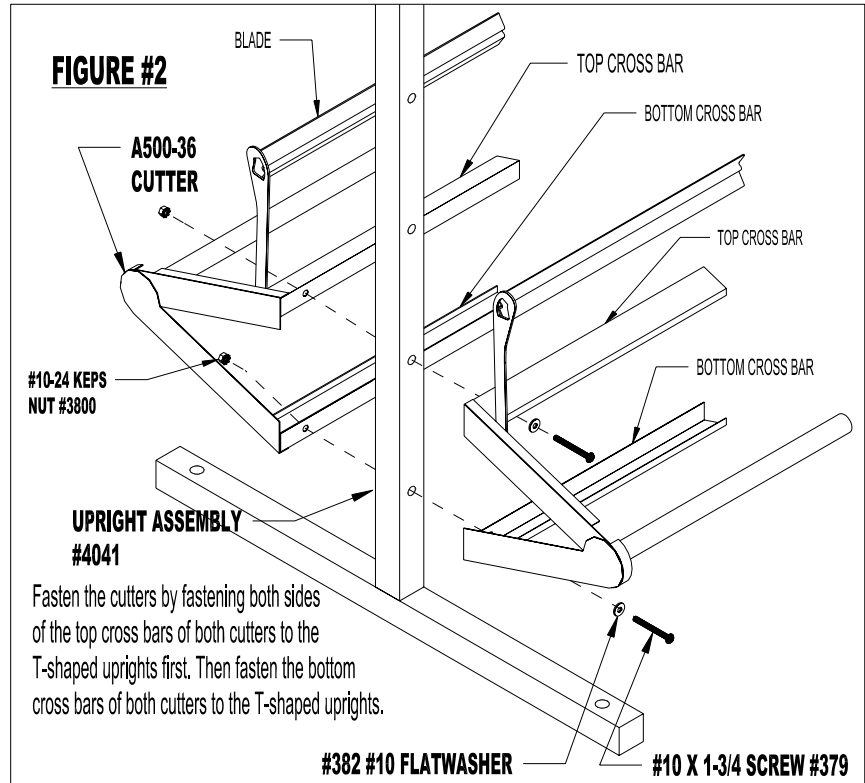
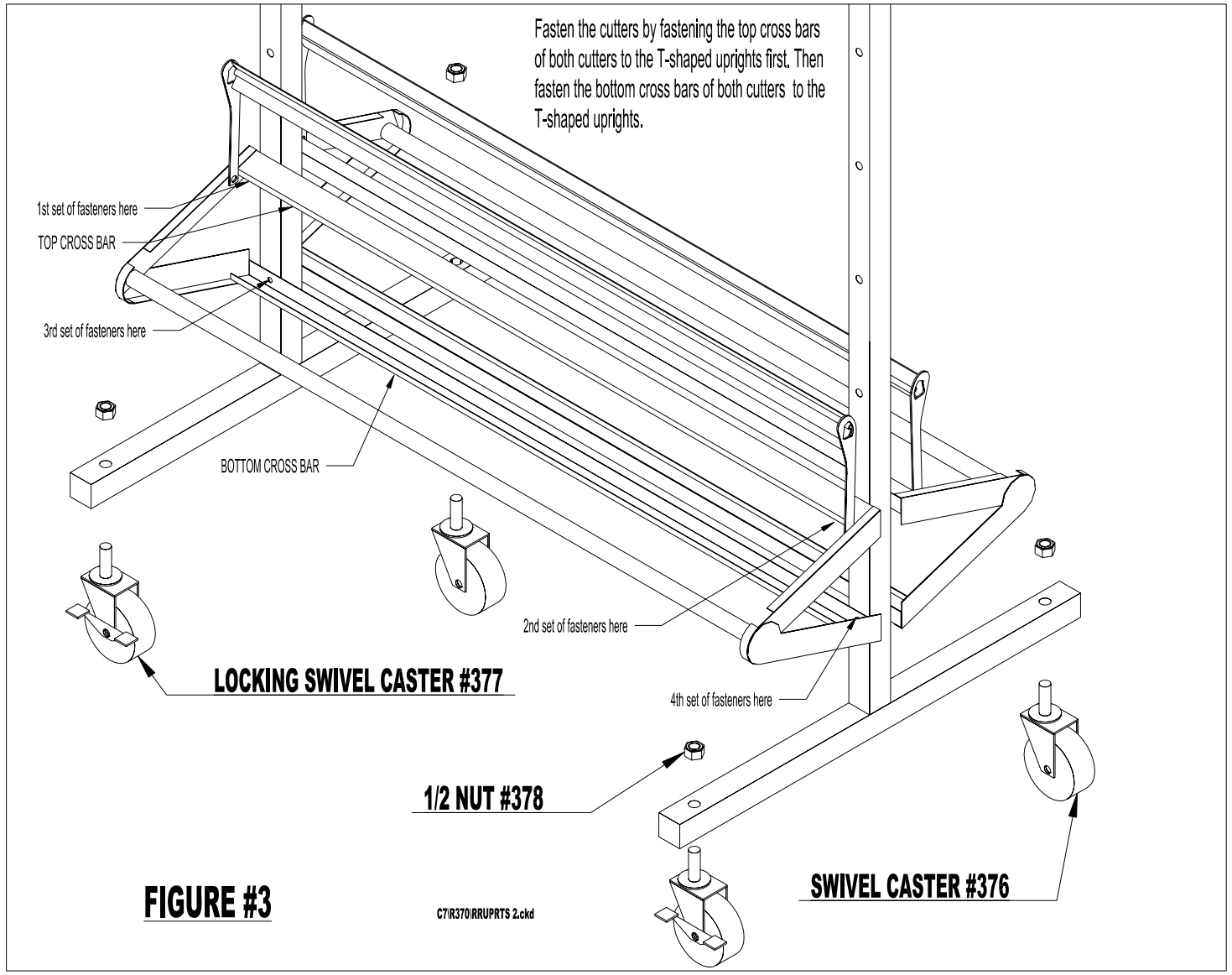

FIGURE #2

Fasten the cutters by fastening both sides of the top cross bars of both cutters to the T-shaped uprights first. Then fasten the bottom cross bars of both cutters to the T-shaped uprights.



Fasten the cutters by fastening the top cross bars of both cutters to the T-shaped uprights first. Then fasten the bottom cross bars of both cutters to the T-shaped uprights.

FIGURE #3