

GALVANITE K. D. WARDROBE STOCK LOCKER ASSEMBLY INSTRUCTIONS

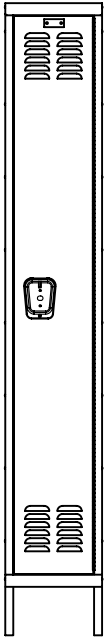

1 WIDE

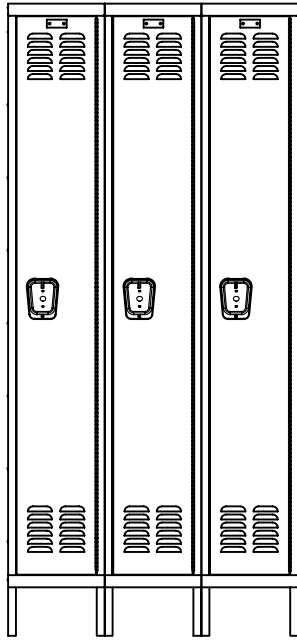

3 WIDE

SINGLE TIER

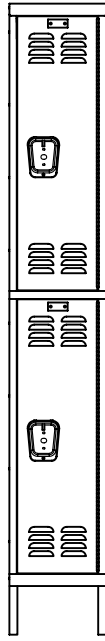

1 WIDE

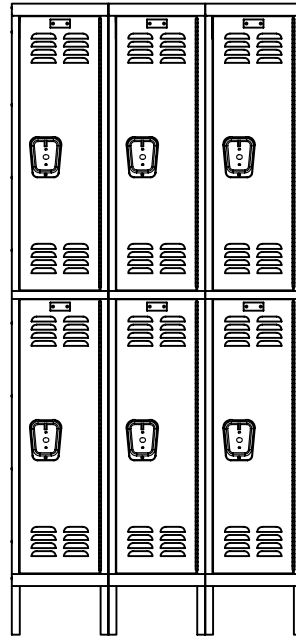

3 WIDE

DOUBLE TIER

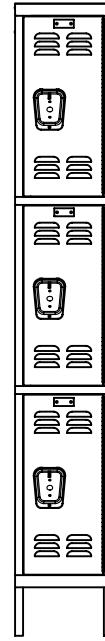

1 WIDE

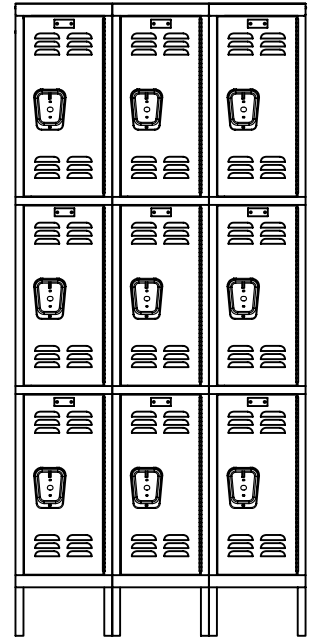

3 WIDE

TRIPLE TIER

General Instructions

1. Check material received against the packing list. First check the number of packages received and then check the contents of each package.
2. Check material received for damage. If damage has occurred, secure a "damage notation" from the carrier.
3. Identify each part as it is unpacked and put like parts together as close as possible to the working area in which they are to be assembled.
4. Be careful to use the correct hardware as specified in the assembly instructions.
5. Items with suffix (xx) are available options.

CAUTION

IN THE INTEREST OF SAFETY, ALL LOCKERS MUST BE SECURELY ANCHORED TO THE FLOOR AND/OR WALL.
FOR SAFETY, HANDLE ALL COMPONENTS CAREFULLY AND WEAR WORK-GLOVES WHEN ASSEMBLING LOCKERS.

INSTALL ALL UNITS PLUMB AND TIGHTEN ALL HARDWARE SECURELY.

RETAIN INSTRUCTIONS FOR FUTURE REFERENCE.



2823 W. Orange Ave.
Apopka, FL 32703

Phone (866) 566-0500
Fax (407) 464-3610

www.Hallowell-List.com

GALVANITE K.D. WARDROBE STOCK LOCKER ASSEMBLY INSTRUCTIONS

PACKAGE CONTENTS

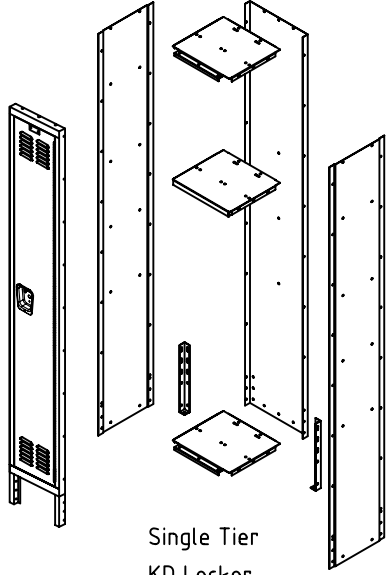
REF. NO.	DESCRIPTION	PART NO.	1-WIDE QUANTITY			3-WIDE QUANTITY			
			1-TIER	2-TIER	3-TIER	1-TIER	2-TIER	3-TIER	
①	REAR PANEL	KRwwhhG	1	1	1	3	3	3	 <p>Single Tier KD Locker</p>
②	RIGHT/LEFT SIDE PANEL	KPddhhG	2	2	2	4	4	4	
③	TOP/BOTTOM SHELF	KSwwddG	2	3	4	6	9	12	
④	HAT SHELF	KHwwddG	1	-	-	3	-	-	
⑤	SINGLE CEILING HOOK	H5K	2	4	-	6	12	-	
⑥	DOUBLE CEILING HOOK	H7K	1	2	3	3	6	9	
xx⑦	COAT ROD BRACKET	TRH200	2	4	-	6	12	-	
xx⑧	COAT ROD	KCRww	1	2	-	3	6	-	
⑨	DOOR FRAME ASSEMBLY	KDHFwwhh-tLV-G	1	1	1	3	3	3	
x⑩	DOOR	KDHwwhh-tLV-G	1	2	3	3	6	9	
x⑪	RECESSED HANDLE S.S.	TBECK2	1	2	3	3	6	9	
x⑫	LOCK CHANNEL	KLhh-t	1	2	3	3	6	9	
x⑬	CHANNEL STOP	CS002	2	4	6	6	12	18	
x⑭	NYLON LATCH	DLB100B	2	4	6	6	12	18	
x⑮	SPRING	LS100	2	4	6	6	12	18	
x⑯	LOCK BRACKET	SLB101L	1	2	3	3	6	9	
x⑰	PLASTIC LIFTER	LC100B	1	2	3	3	6	9	
⑱	REAR LEG	KLG	2	2	2	2	2	2	
x⑲	BUMPER	KDB300	3	4	6	9	12	18	
⑳	NUMBER PLATE	NPH	1	2	3	3	6	9	
㉑	NUMBER PLATE RIVET	RV101	2	4	6	6	12	18	
㉒	3/8" SLOTLESS BOLT	MBT200	62	74	70	134	166	188	
㉓	HEX NUT	N201	60	70	64	128	154	170	
㉔	ESCUTCHEON PLATE	RPE100	1	2	3	3	6	9	
㉕	HI-DOME CAP NUT	N110	2	4	6	6	12	18	
x㉖	RIVET (HANDLE)	RV102	1	2	3	3	6	9	
x㉗	RIVET (HINGE)	RV102	7	8	9	21	24	27	

PART NUMBER SUFFIX SHOWS WIDTH, DEPTH, HEIGHT AND TIER. CUSTOMER TO SPECIFY.

NOTE:

FOR OPTIONAL INDIVIDUAL SLOPE TOPS,
SEE SUPPLEMENTAL INSTRUCTION SHEET NO. ASY-H-KIST-A

FOR OPTIONAL 6" HIGH CLOSED METAL BASE,
SEE SUPPLEMENTAL INSTRUCTION SHEET NO. ASY-H-KIST-B

x SHIPS PRE-HUNG IN DOOR FRAME ASSEMBLY ⑨

xx OPTIONAL ITEM

PART NO. LEGEND:

ww = WIDTH
dd = DEPTH
hh = HEIGHT (FRAME)
t = TIER

TOOLS REQUIRED: 3/8" NUT DRIVER (3/8" SOCKET MAY BE SUBSTITUTED)

TWO-YEAR WARRANTY

HALLOWELL K.D. LOCKERS ARE COVERED AGAINST ALL DEFECTS IN MATERIALS AND WORKMANSHIP EXCLUDING FINISH, DAMAGE RESULTING FROM DELIBERATE DESTRUCTION AND VANDALISM FOR A PERIOD OF TWO YEARS.



GALVANITE K.D. WARDROBE STOCK LOCKER ASSEMBLY INSTRUCTIONS

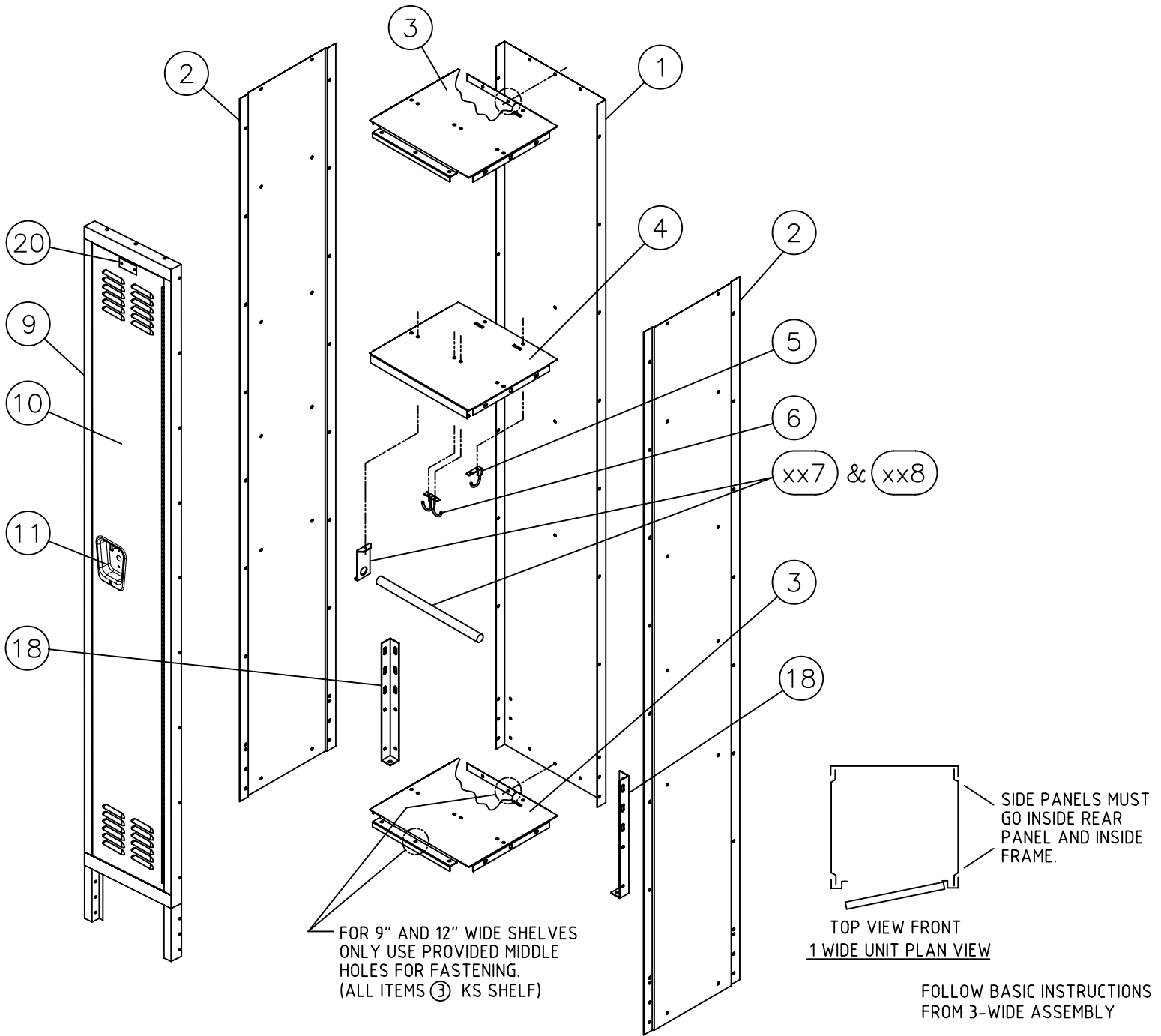

COAT ROD (KCRww) & COAT ROD BRACKETS (TRH 200) ARE OPTIONAL.

HALLOWELL MAKES EVERY EFFORT TO ENSURE THAT ALL UNITS SHIP COMPLETE; HOWEVER, SHOULD YOUR UNIT CONTAIN MISSING OR DAMAGED PARTS, REPLACEMENTS MAY BE OBTAINED FROM HALLOWELL. TO OBTAIN PARTS, FOLLOW THESE INSTRUCTIONS.

PLEASE PROVIDE THE FOLLOW INFORMATION:

MODEL NUMBER

PURCHASE DATE

DESCRIPTION OF PART(S) NEEDED & PART NUMBER(S) AS SHOWN IN PARTS LIST

COMPANY NAME & CONTACT PERSON

COLOR

WHERE THE PRODUCT WAS PURCHASED FROM

IF REQUESTING PARTS BY TELEPHONE, ASK FOR CUSTOMER SERVICE & PROVIDE THE ABOVE INFORMATION.



GALVANITE K.D. WARDROBE STOCK LOCKER ASSEMBLY INSTRUCTIONS

(A GROUPING OF 3-WIDE SINGLE TIER LOCKERS ILLUSTRATED)

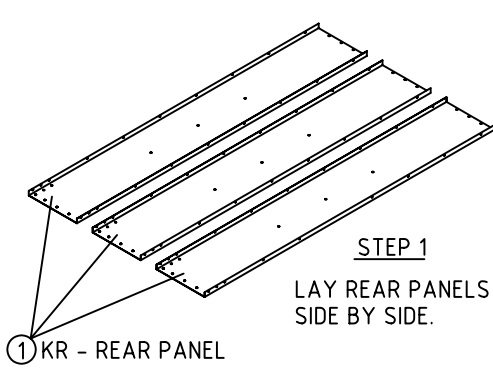

STEP 1
LAY REAR PANELS
SIDE BY SIDE.

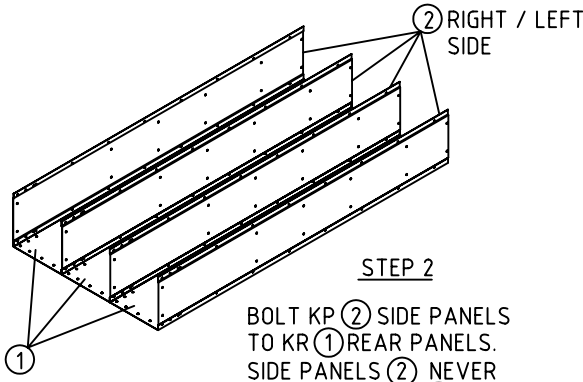

STEP 2
BOLT KP (2) SIDE PANELS
TO KR (1) REAR PANELS.
SIDE PANELS (2) NEVER
FIT BETWEEN KR (1) REAR
PANEL FLANGES.

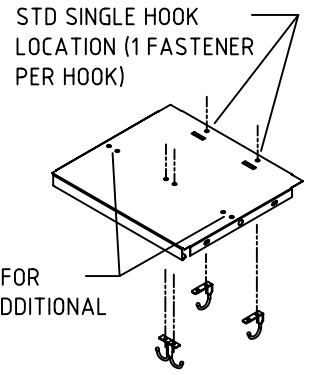

STD SINGLE HOOK
LOCATION (1 FASTENER
PER HOOK)

STEP 3
INSTALL DOUBLE CEILING
HOOK (H7K) (6) AND SINGLE
CEILING HOOKS (H5K) (5)
TO (KH) (4) HAT SHELF.

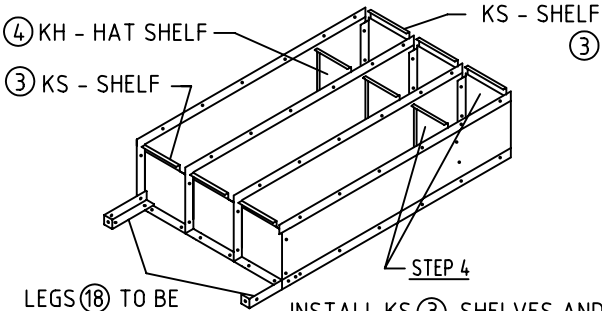

STEP 4
INSTALL KS (3) SHELVES AND
KH (4) SHELVES TO UNIT.
INSTALL TWO KLG (18) REAR
LEGS TO INSIDE OF SIDE (2) AND REAR
PANEL (1) BY SLIDING INTO PLACE FROM BOTTOM.

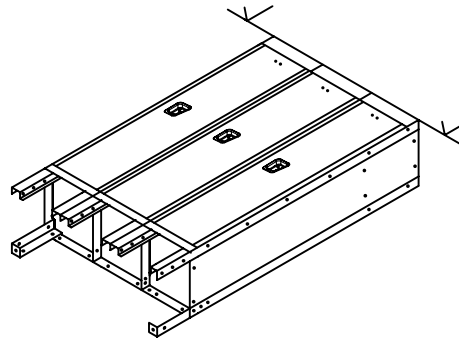

STEP 5
BOLT DOOR AND FRAME (9) ASSEMBLIES
TO KS (3) SHELVES AND KP (2) SIDE
PANELS. STAND UNIT UP AND ALIGN
LOCKER TOPS EVENLY. TIGHTEN ALL
BOLTS AND NUTS.
NOTE: WHEN BOLTING ONE UNIT TO
ANOTHER, OMIT ONE SET OF BOLTS
IN END FRAME AND SIDE TO MINIMIZE
GROWTH FROM BOLT HEADS.

ASSEMBLY OF SINGLE ROW LOCKERS
NEVER PUT SIDE PANELS BETWEEN
FRAMES OR REAR PANELS.

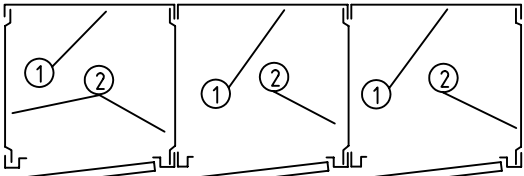

SINGLE TIER EXAMPLE - 3 WIDE UNIT PLAN VIEW

SIDE PANELS MUST
GO INSIDE REAR
PANEL AND INSIDE
FRAME.

OPTIONAL COAT ROD

BRACKETS TO BE BOLTED TO UNDERSIDE
OF HAT SHELF WITH COAT ROD IN BETWEEN.

xx (7) COAT ROD BRACKETS (xxTRH 200)
xx (8) COAT ROD (xxKCRww)

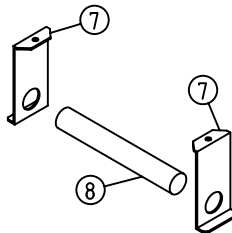

(6) DOUBLE CEILING HOOK (H7K)

TO BE BOLTED TO
UNDERSIDE OF HAT SHELF.

(5) SINGLE CEILING HOOK (H5K)

TO BE BOLTED TO
UNDERSIDE OF HAT SHELF.

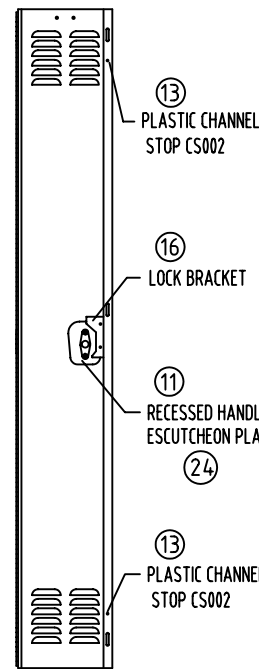

INSIDE DOOR VIEW

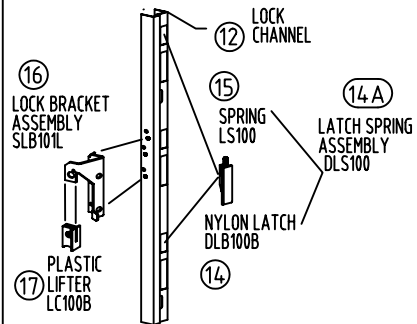

EXPLODED VIEW OF LOCK CHANNEL

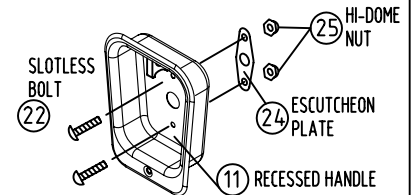

ASSEMBLY OF ESCUTCHEON PLATE

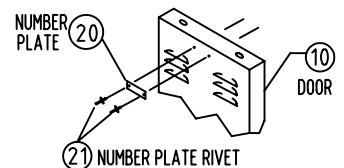

ASSEMBLY OF NUMBER PLATE

