

AQUAMAX™

INSTALLATION INSTRUCTIONS

General Instructions

1. Check material received against the packing list. Check the number of packages received and then check the contents of each package.
2. Check the material received for damage. If damage has occurred, secure a “damage notation” from the carrier
3. Identify each part as it is unpacked and put like parts together as close as possible to the working area where they are to be assembled.
4. Be careful to use the correct hardware as specified in the assembly instructions.

CAUTION

In the interest of safety, all lockers must be securely anchored to the floor and/or wall. For safety, handle all components carefully and wear work gloves when assembling lockers. Install all units plumb and tighten all hardware securely. Retain instructions for future reference.



866-566-0500
info@Hallowell-List.com
www.Hallowell-List.com

1. Tools Required

- Tape Measure
- 4 ft. Level
- Laser Level
- Stud Finder
- Ratchet Bit Driver (Torx drive bits supplied)
- Flat Head Screw Driver
- Phillips Head Screw Driver
- Drill
- Screw Gun
- Rubber Mallet
- Belt Sander
- Circular Saw
- Miter Saw
- Chalk Snap Line
- 1/4" Drill Bits
- 7/32" Drill Bits
- 1/8" Drill Bits
- Cedar Shims

2. Getting Started

- 2.1 Find the packing list in the box marked "Packing List".
- 2.2 Check the delivered materials and make sure there are no parts damaged or missing. Note any missing or damaged material on freight bill.
- 2.3 Open the hardware box and organize the hardware packages. Do not open the packages until they are called for during the installation procedures.
- 2.4 Locate the drawings sent with the shipment and confirm that the field dimensions match the room.
- 2.5 Clean the area prior to installing lockers and clear enough room to provide an adequate work area.

3. Locker Layout

- 3.1 Using the top view locker layout sheet, mark on the walls the starting and ending point of each run of lockers. (fig 3.1)
- 3.2 Establish the highest point of the floor or cement curb in the room where the lockers will be installed. Use your laser level to determine this, or a level and a tape measure.
- 3.3 Using the front view of the locker layout sheet locate the height of the locker. (fig 3.2) If you are installing the lockers on a cement curb then mark this dimension at the highest point of the cement curb. If you are installing the lockers on adjustable mounting feet then add 4 1/16 inches to this dimension and mark on wall.
- 3.4 Using your laser level transfer this location on the walls where the lockers are to be installed. (fig 3.3 & 3.4)

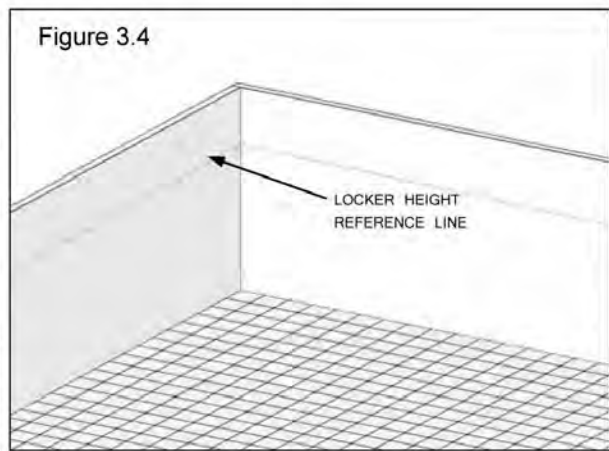
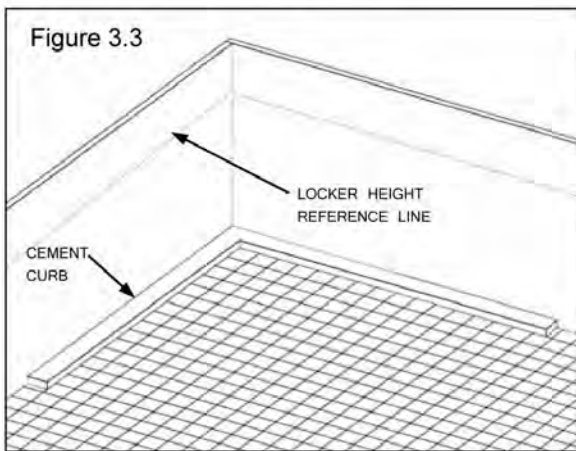
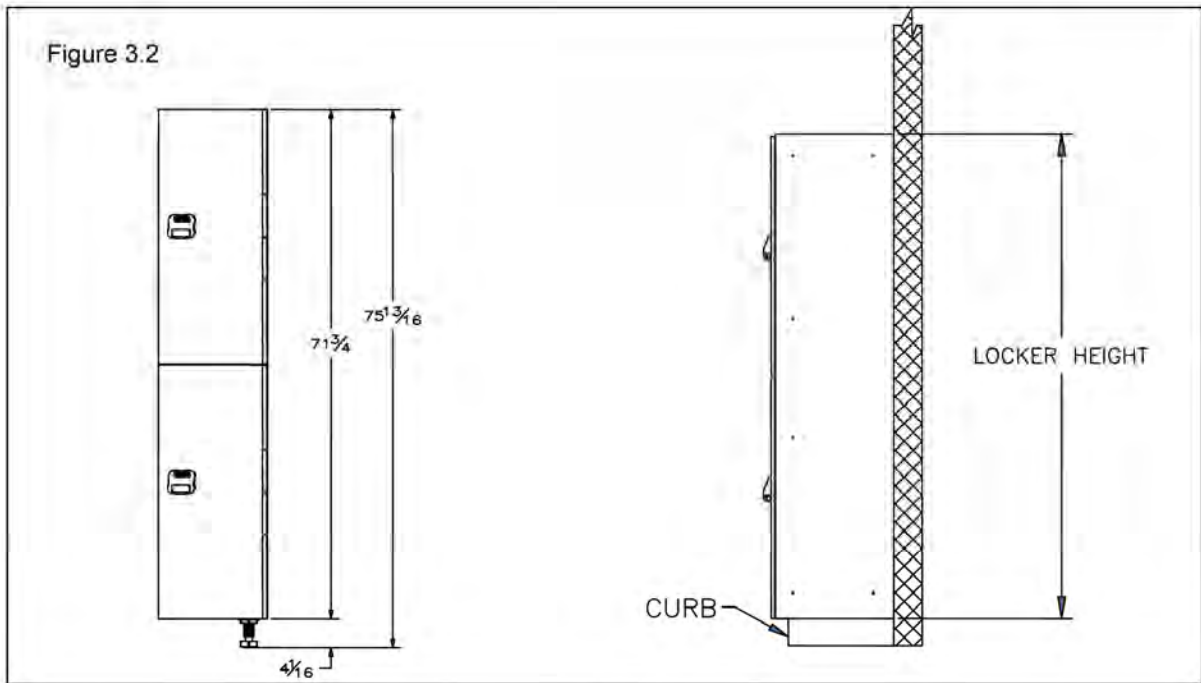
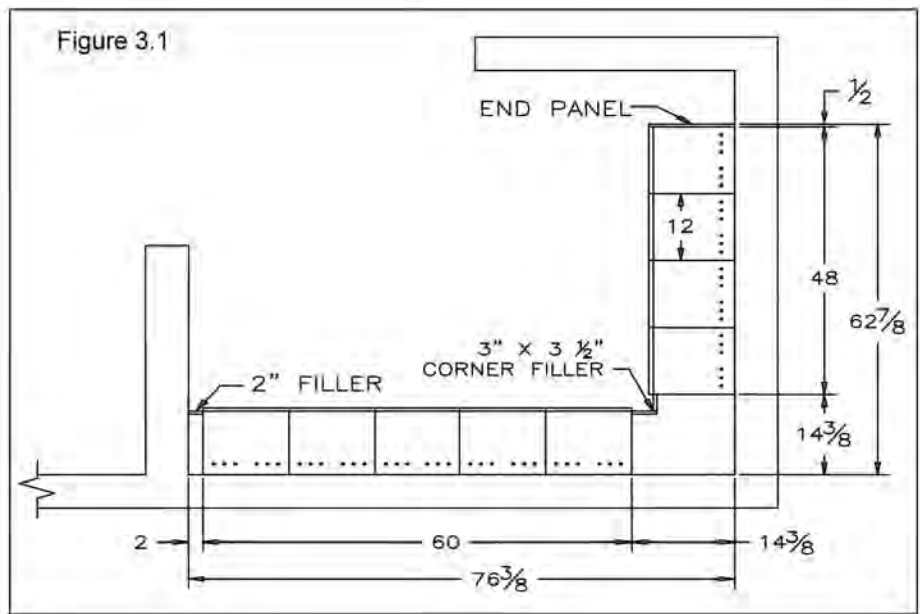

4. Locker Feet

If your lockers are mounting to a cement curb proceed to step 5.

- 4.1 Locate the locker feet hardware. (Fig 4.1)
- 4.2 Lay the locker on its back and open the door.
- 4.3 Install the leg screw through the predrilled holes in the bottom of the locker. (Fig 4.2)
- 4.4 Screw the locker adjustable leg onto the leg screw and tighten. (Fig 4.3)
- 4.5 Install the white screw caps on the locker leg screw. (Fig 4.4)
- 4.6 Adjust the locker leg to 4 1/16" from bottom of locker.

Figure 4.1



Figure 4.2



Figure 4.3

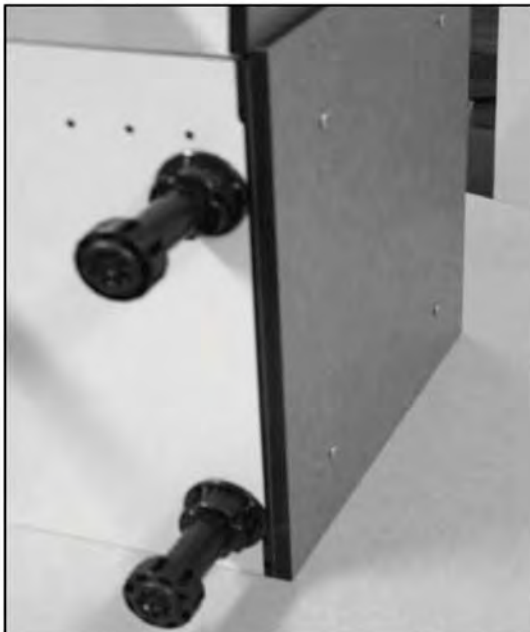
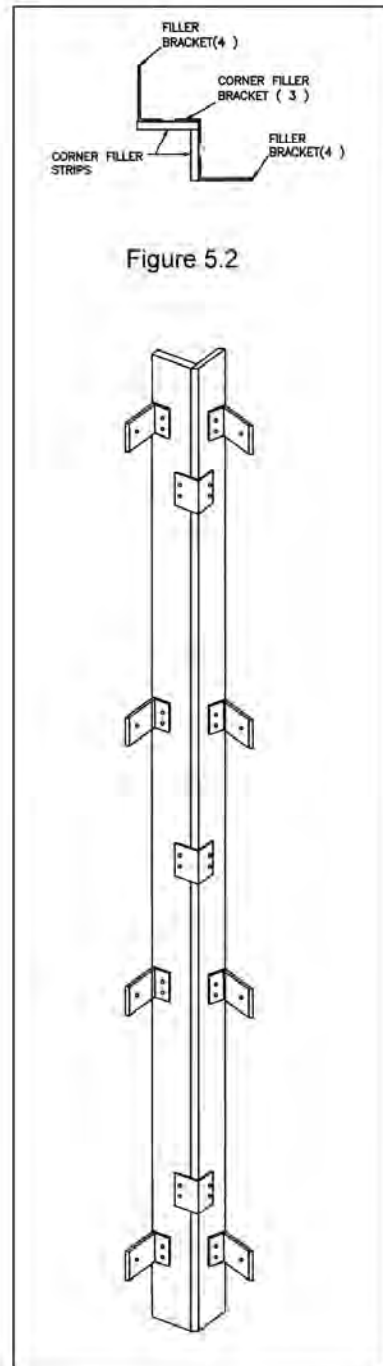
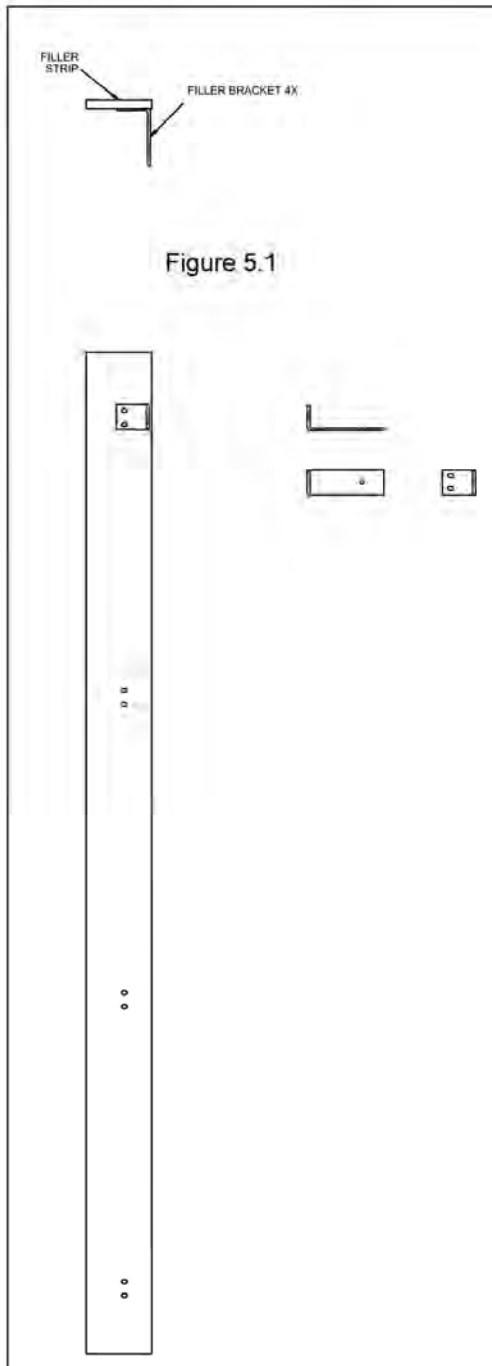

Figure 4.4



5. Filler Strips & Corner Fillers

- 5.1 Locate the filler strips and corner fillers.
- 5.2 Install the filler strip brackets on the filler strips using the filler strip screws provided. (Fig 5.1)
- 5.3 Assemble the corner fillers using (3) corner filler brackets. Install (4) filler strip brackets to each corner filler strip as shown using the filler strip screws provided. (Fig 5.2)



6. Locker Installation

- 6.1 Note: When using adjustable feet install locker runs from left to right where possible to provide access to adjust the legs. Locker installation must always start from the corner for applications using a corner filler.
- 6.2 Have at least (4) lockers prepared with the adjustable leveling feet if applicable.
- 6.3 Starting in the corner or wall where the run of lockers begin, stand (2) lockers up and thru-bolt the side panels together. (Fig 6.1) Use the locker connecting bolts and barrel nuts provided. There will be 6 fasteners for each side to side locker connection. (Fig 6.2)
- 6.4 Space these lockers from the corner according to the dimension given in the top layout. (Fig 6.3)
- 6.5 Adjust the height of the lockers to the leveling line and square up the lockers using cedar shims (for curb mounted) or adjustable feet.
- 6.6 Drill a $\frac{1}{4}$ " hole through the back of the lockers 6" down from the locker top, inline with a wall stud. Install a locker to wall screw to hold the lockers in place.
- 6.7 Install the proper filler or corner filler to the first locker using the supplied #10-24 x $\frac{3}{4}$ " screws. Insert them into the top and bottom connecting holes predrilled in the locker bodies. The holes in the filler bracket will align with the holes in the side panel. (Fig 6.4)
- 6.8 For corner filler applications: Repeat steps 6.2 thru 6.5 for the (2) lockers to be installed on the adjacent wall. Proceed to step 6.10 if starting the run with a standard filler.
- 6.9 Position the adjacent lockers at the corner so that the corner filler brackets align with the locker side panel. Level the lockers and attach the corner filler to the locker. (Fig 6.5) Repeat step 6.6 to anchor these lockers to the wall.
- 6.10 Install the adjustable feet on each locker and finish installing the rows of lockers. (Fig 6.6)
- 6.11 Install the proper filler strip at the end where the locker run stops at a stub wall. Pre fit the filler panel and scribe as necessary to the wall.
- 6.12 Make sure the lockers are plumb and level. Install the locker to wall screws into the remaining studs. Drill $\frac{1}{4}$ " hole in back of locker 6" down and install screws.

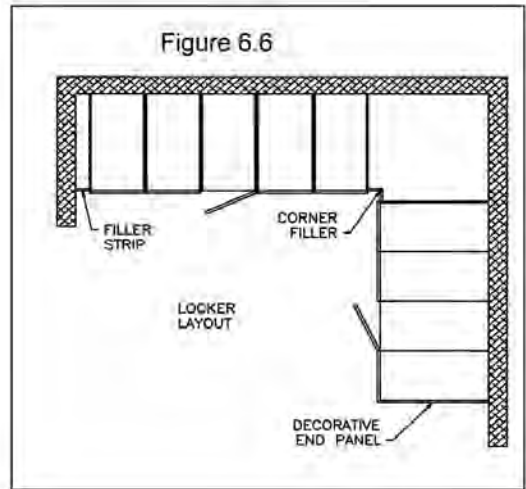
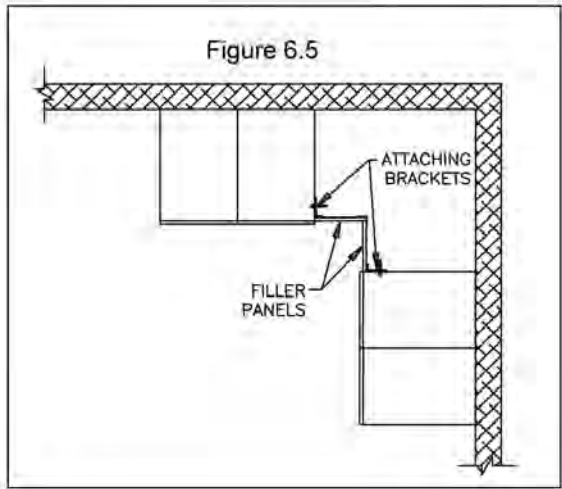
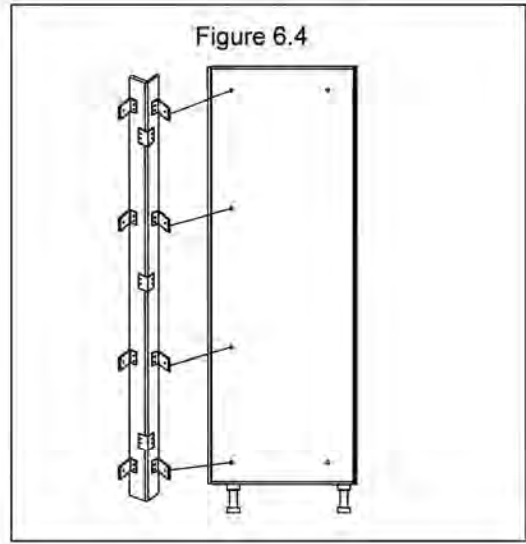
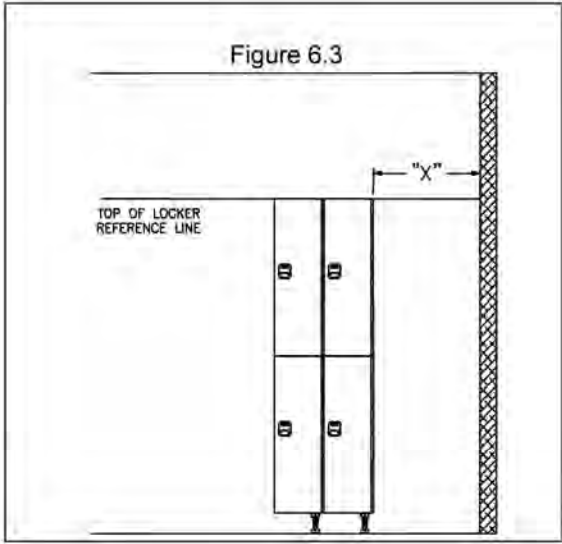
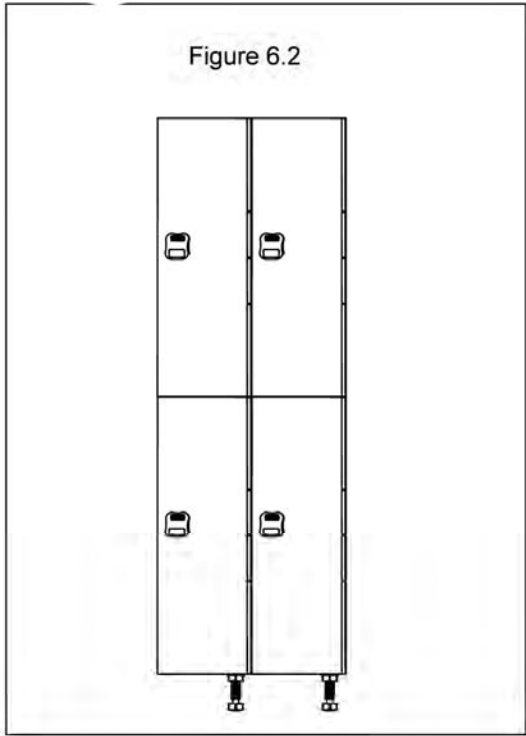
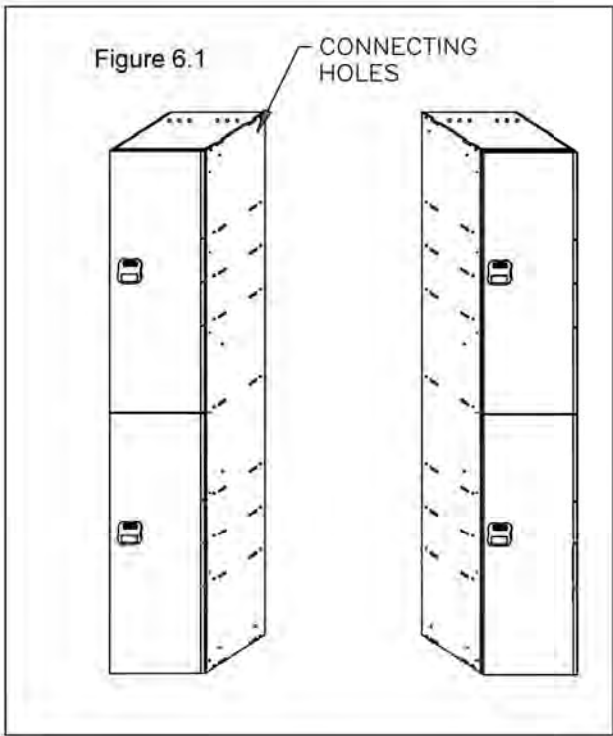

7. Sloped Top Installation

If the project does not have sloped tops then continue on to step 8.

- 7.1 Locate the sloped top brackets and install them on the lockers as indicated on the shop drawings. Install them by inserting a #14 x 1" screw thru the inside of the top of the locker vent holes.
- 7.2 Locate the aluminum sloped top channels and cut the top channels to length as required. Peel off outer layer of adhesive strip to install the channels along front edge of locker body.
- 7.3 Attach the rectangular sloped top panels by drilling a 7/32" hole thru the sloped top and the aluminum sloped top bracket. Using the 7/32" hole as a pilot, run a 1/4" drill thru only the sloped top panel to give clearance for the mounting screw. Use the #14 x 1" sloped top screws to attach the top panel to the brackets. (Fig 7.1)
- 7.4 Locate the mitered sloped top panel and test fit it and scribe as necessary.
- 7.5 Install the mitered sloped top panel using the same procedure as described in step 7.3. (Fig 7.2)
- 7.6 Use caulking to fill any voids between the wall and the sloped tops.

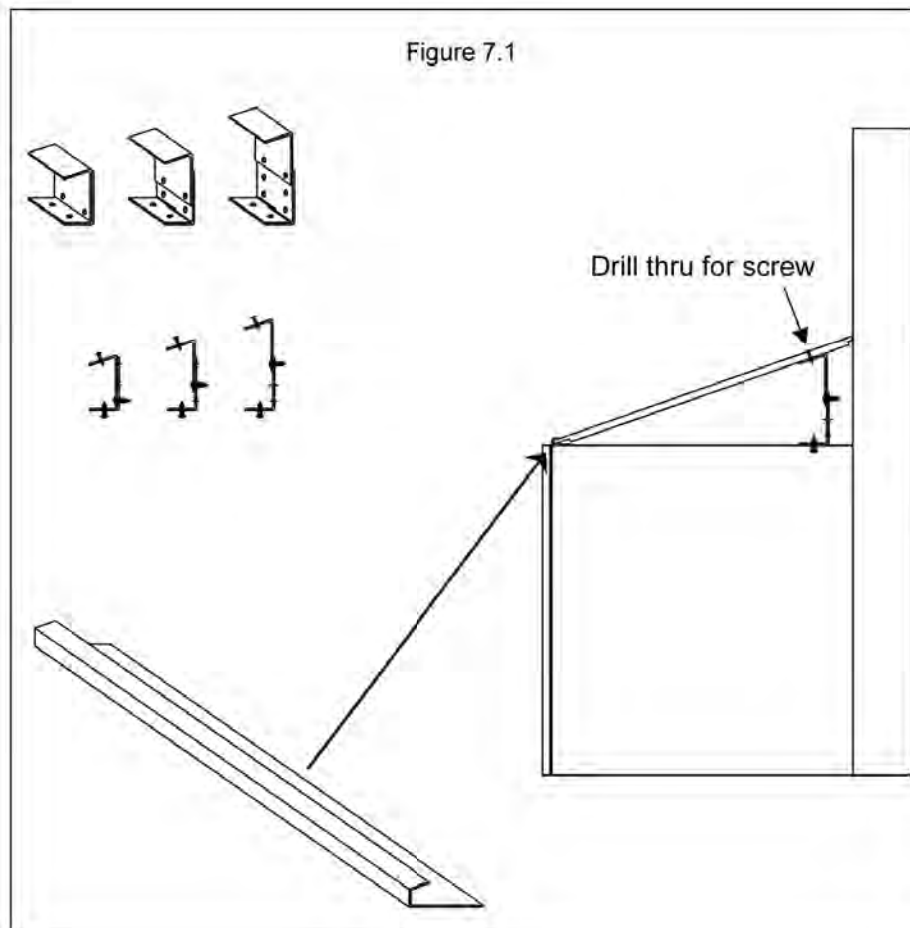
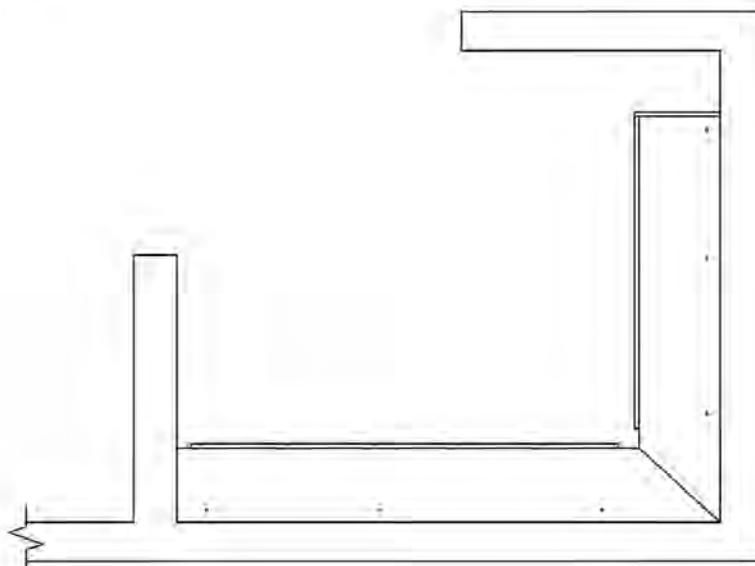
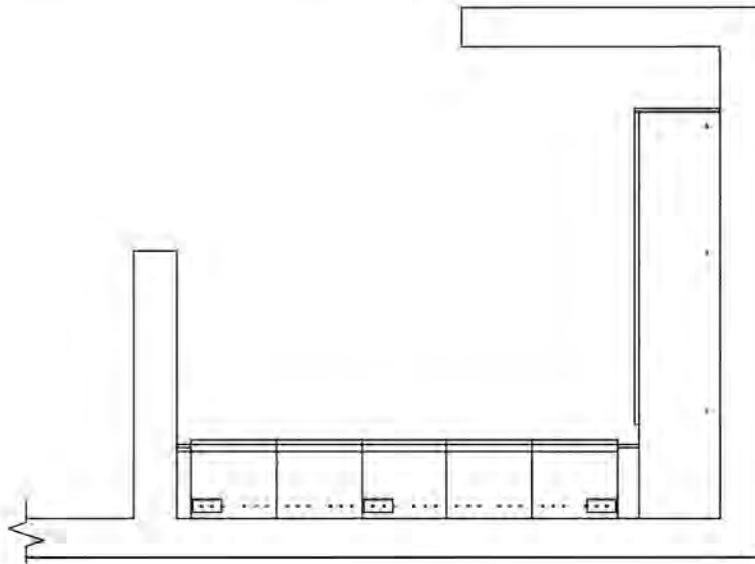
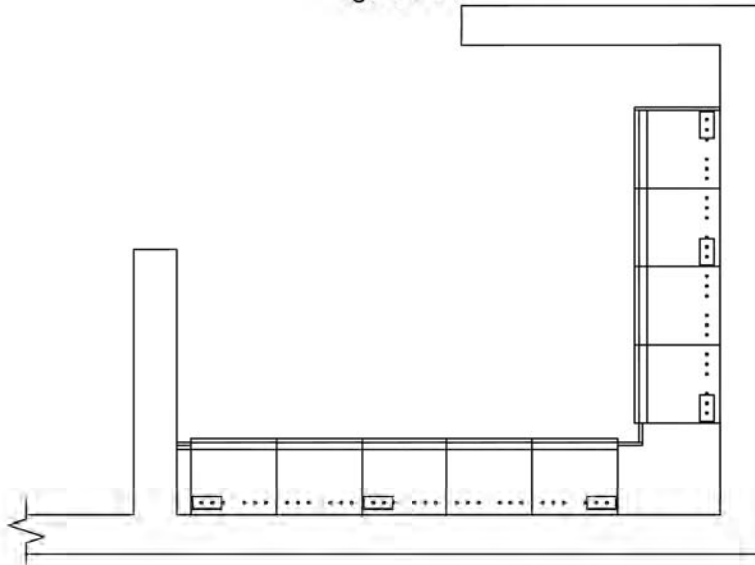

Figure 7.2



8. Toe Kick Installation

If the project does not have this base system then proceed to step 9.

- 8.1 Locate the toe kick strips and align them under the lockers in the positions they belong. Refer to the shop drawings for their locations.
- 8.2 It will be necessary to cut the ends of the toe kick plates where the parts end at a wall or corner. Use the miter saw with a carbide tip blade to trim them to length.
- 8.3 Measure the distance from the floor to the bottom of the locker at the beginning and end of where the toe kick will be installed. Trim the toe kick to allow a minimal amount of clearance for the toe kick to fit under the lockers.
- 8.4 Insert the toe kick under the locker run in the proper position against the locker legs. Using a 1/8" drill bit drill a hole into the toe kick strip using the predrilled hole in the bottom of the locker as a pilot hole. (Fig. 8.1)
- 8.5 Insert a FA-930 screw into the toe kick from inside the locker and tighten. Follow this procedure for each locker.
- 8.6 For toe kick mounting to the side of a locker use the provided toe kick clips.
- 8.7 Mark the center locations of the legs on the back side of the toe kick plates.
- 8.8 Locate the toe kick clip mounting plates and mark the two hole locations on the back of the toe kick. Drill a 1/8" diameter hole into the plate 3/8" deep. The use of masking tape on the drill bit or a block is helpful to avoid drilling through the toe kick plate. Install the #6 x 3/8" screws through the mounting plate and into the toe kick plate.
- 8.9 Slide the toe kick clip under the tabs on the mounting plate. These are adjustable for the proper alignment with the legs.
- 8.10 Install the toe kick plate on the legs of the locker by pressing or tapping with a rubber mallet on the face of the toe kick plate and snapping the clip onto the legs. (Fig. 8.2)

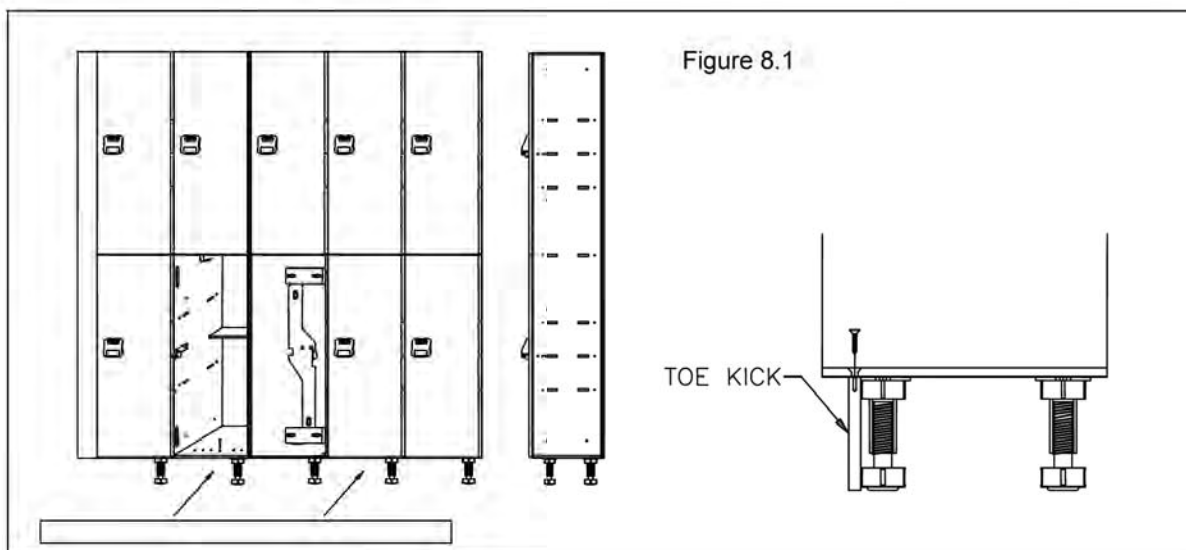

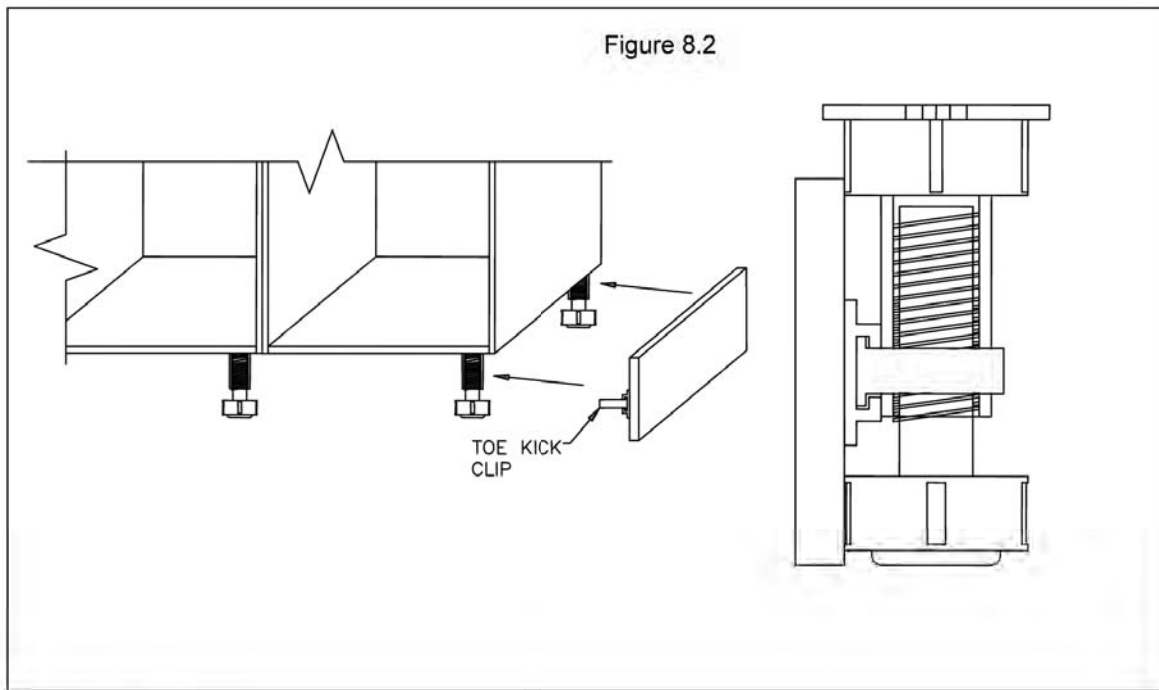

9. I.D. Plates

- 9.1 Locate the number plates. Refer to the shop drawings for the numbering sequence to be followed.
- 9.2 Attach number plates with fasteners provided.