

FRONT VIEW

Backrest can be pulled up and down. Raise the backrest to the top position when you would like to adjust it to the initial position.

The Mechanism with Multi-Functions

- **Pneumatic Seat Height**
Control Seat height can be adjusted
- **Seat Angle Control**
Seat angle can be adjusted independently
- **Back Angle Control**
Back can be adjusted and locks at desired positions
- **Back Height Adjustments**
Back can be adjusted up and down by ratchet for various back height
- **Control of Seat Forward Tilt**
Lock and release of forward tilt for intensive keyboard activities
- **Adjustable Tilt/Tension Control**
Tension of seat & back tilt can be increased or decreased as desired

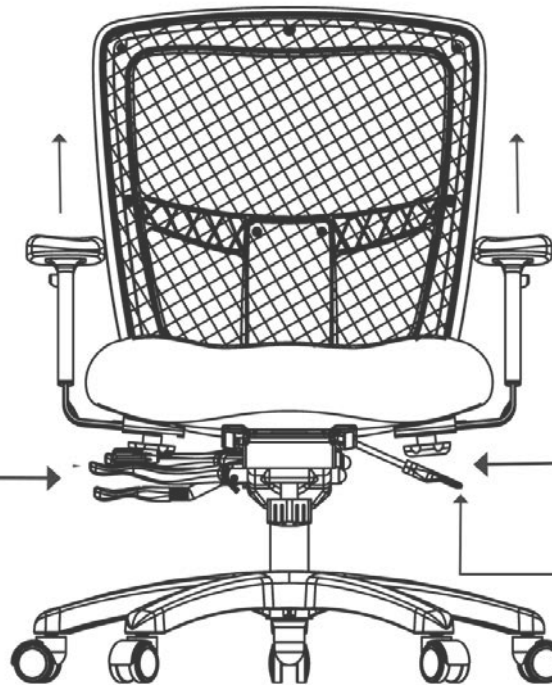

Press this button to adjust the up and down of the armrest.











The lock button can adjust the armrest width.

Seat Slider can slide seat back and forth by up to 2" and lock in 4 positions.



NOTE: Carefully check all parts according to the instructions before assembling. Please assemble carefully to avoid scratching surfaces, especially powder-coated surfaces.

Parts & Hardware

Item	Parts	Qty.	Item	Parts	Qty.
A	 Back Assembly	1	H	 Inner Hexagon Screw 5/16" x 3/4"	3
B	 Seat Assembly	1	I	 Flat Pad 16" x 8.3" x 2.0mm	3
C	 Armrest L/R	1	J	 Wrench	1
D	 Gas Lift	1	K	 Dust Cover	1
E	 Base	1			
F	 Caster	1			
G	 Adjusted Width Button	2			

ASSEMBLY GUIDE

1. Assemble the Base, Casters, Gas Lift & Dust Cover

Insert five casters [F] into the base. Push hard until you feel or hear the caster [F] snap into place. With the base [E] upright and the casters [F] on the floor, insert the gas lift [D] into the base [E]. Then, put the dust cover [K] on the gas lift [D].

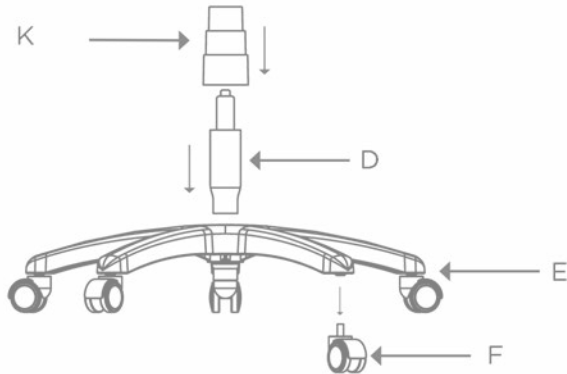

3. Assemble the Armrest & Seat

Attach the armrests [C] to the seat assembly [B] using the adjusted width button [G] to fasten the armrests over the seat assembly [B].

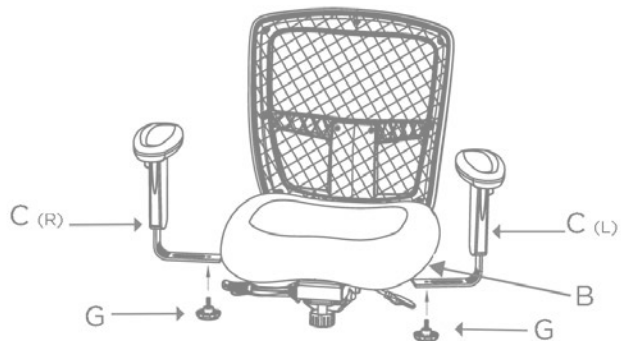

2. Assemble the Seat & Back

Keep the seat assembly [B] on a table first, then insert the back assembly [A] between connected seat assembly [B] and seat plane. Turn the back assembly [A] into the center of three holes. Attach using a wrench [J]. Fully tighten the inner hexagon socket screws [H] and flat pad [I].

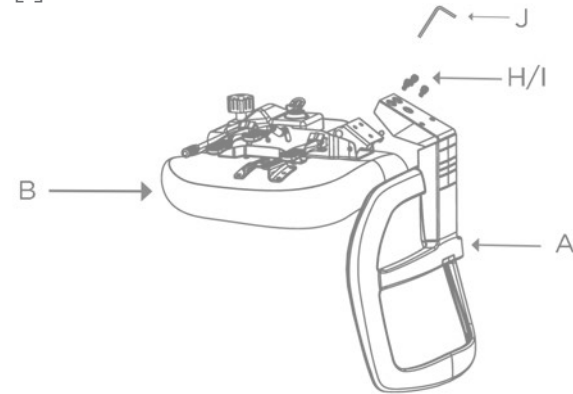

4. Assemble the Seat & Gas Lift

Insert the seat assembly [B] with the armrests into the gas lift [D].

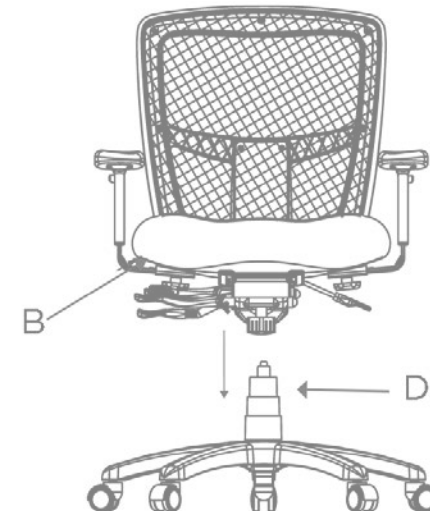

PRODUCT DIMENSIONS

