

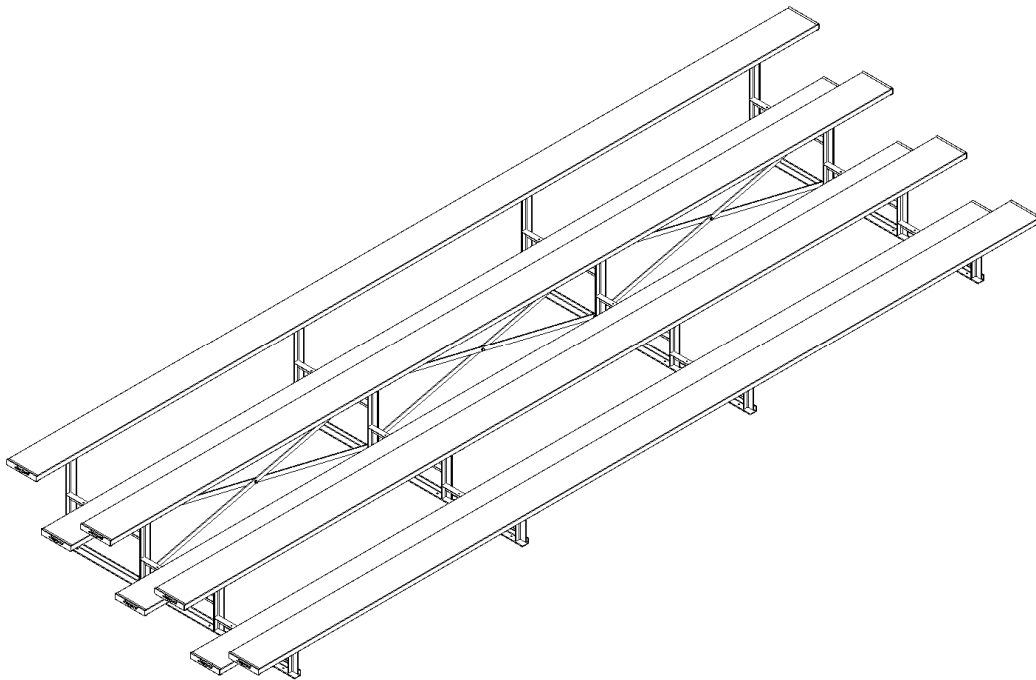

**-- 4 ROW, 15 & 21 FT BLEACHER with
GALVANIZED STEEL UNDER CARRIAGE --
(STANDARD OUTDOOR)
Installation Instructions**

BLCH-4 → 4 Row, 15 Ft Aluminum Seat Bleacher w/ galvanized steel undercarriage.
BLCH-421 → 4 Row, 21 Ft Aluminum Seat Bleacher w/ galvanized steel undercarriage.



Call Jaypro Sports Equipment at 1-800-243-0533
during regular business hours for technical support.

www.jaypro.com

JAYPRO SPORTS

4 ROW, ALUMINUM BLEACHER WITH GALVANIZED LEG PARTS LIST

ITEM	PART #	DESCRIPTION	BLCH-4	BLCH-421
1	BLCH-4L	4 ROW GALVANIZED STEEL LEGS	3	4
2	BLALX-77	1/4" x 1 1/4" FLAT X-BARS (BLAL-4RX / BLAL-421RX)	4	6
3	AR5043	9 1/2" x 1 1/2" x 15' STADIUM PLANK	7	N/A
4	AR5052	9 1/2" x 1 1/2" x 21' STADIUM PLANK	N/A	7
5	AR5044	5/16" BOLT CLIP	42	56
6	AR5045A	9 1/2" SEAT PLANK END CAP	14	14
7	HB5054	5/16"-18 x 1 1/4" CARRIAGE BOLT, ZP	42	56
8	HN5046	5/16"-18" FLANGE NUT	42	56
9	HS287	3/8"-16 x 1 1/4" HX HD SCREW, ZP	8	11
10	HS5035	#8 x 1/2" PHILIP SCREW, ZP	28	28
11	HW2050	3/8 SAE FLAT WASHER ZP	8	11
12	HN5042	3/8-16 FLANGED LOCK NUT ZP	8	11

Kit # →	BLCH-4K	BLCH-421K
Box # →	1	1

IMPORTANT NOTICE:

- 1) BEFORE EACH USE CHECK EQUIPMENT FOR PROPER CONNECTING HARDWARE AND STRUCTURAL INTEGRITY. REPLACE DAMAGED OR MISSING HARDWARE IMMEDIATELY.
- 2) USE OF THIS EQUIPMENT OTHER THAN INTENDED, MAY BE HAZARDOUS.
- 3) ALTERATION OR MODIFICATION OF THIS EQUIPMENT MAY BE HAZARDOUS AND RESULT IN INJURY. FOR REPAIR OR REPLACEMENT, CONTACT YOUR DEALER OR JAYPRO SPORTS.

ASSEMBLY INSTRUCTIONS

TOOLS REQUIRED:

- (1) 9/16" Socket Wrench and Box Wrench
- (1) 3/4" Socket Wrench and Box Wrench
- (1) Rubber Mallet
- (1) Phillips head screwdriver

- Unpack all parts and check against parts list to ensure that all have been included.
- Inspect all parts for damage. Report any damages to the trucking company.

Assemble Frame:

1. Assemble undercarriage frame as shown in figure 1 & 2. Vertically plumb and square each leg before tightening cross-bracing hardware.

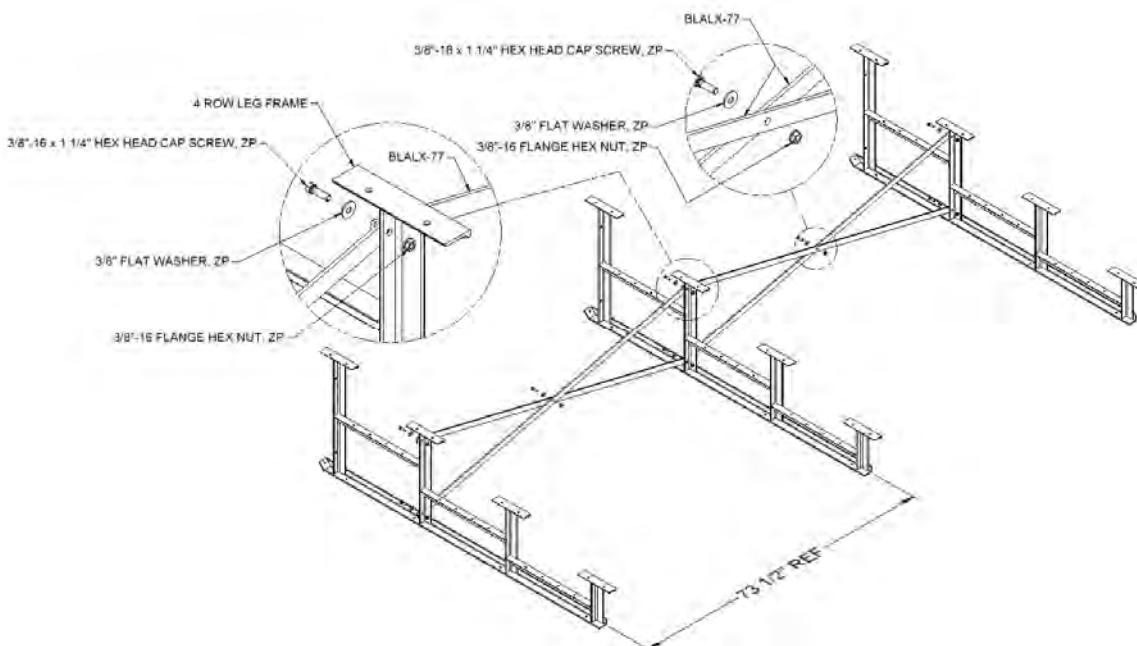

FIGURE: 1
(BLCH-4 shown above)

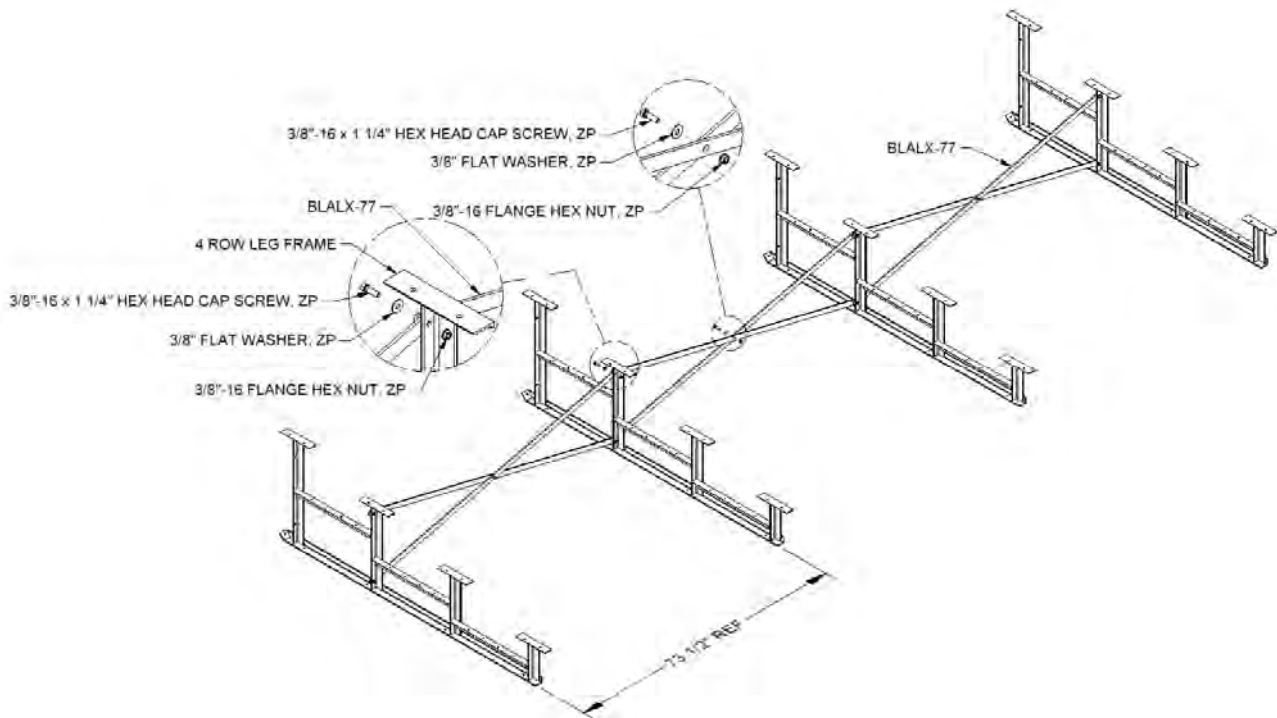

FIGURE: 2
 (BLCH-421 shown above)

Install Seat and Foot Planks:

2. Install end caps on both ends of each plank as shown in figure 3 – lightly tap on with a rubber mallet if necessary. Secure end caps in place using the #8 pan head self-drilling screws.

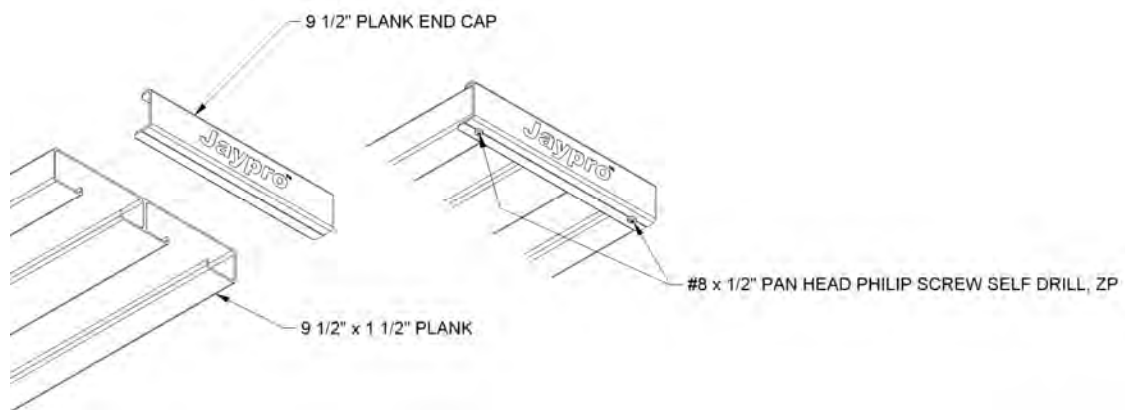

FIGURE: 3

3. Making sure the undercarriage frame is square and plumb, install the seat and foot planks. The seat and foot planks are best installed starting from the front seat and working towards the back. Use the hardware and bolt clip as shown in figure 4 & 5. Position planks so they are centered on the frame, with equal amount of overhang on each end.

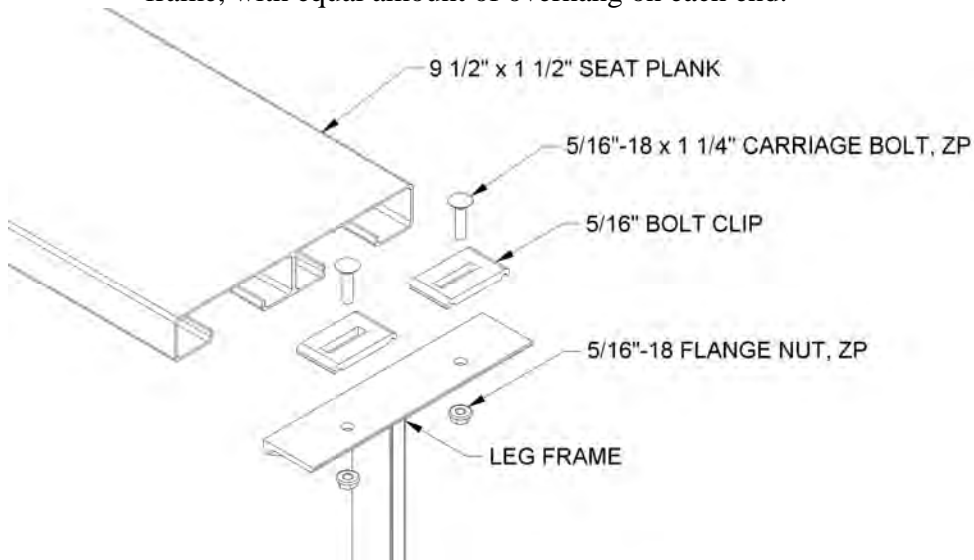

FIGURE: 4

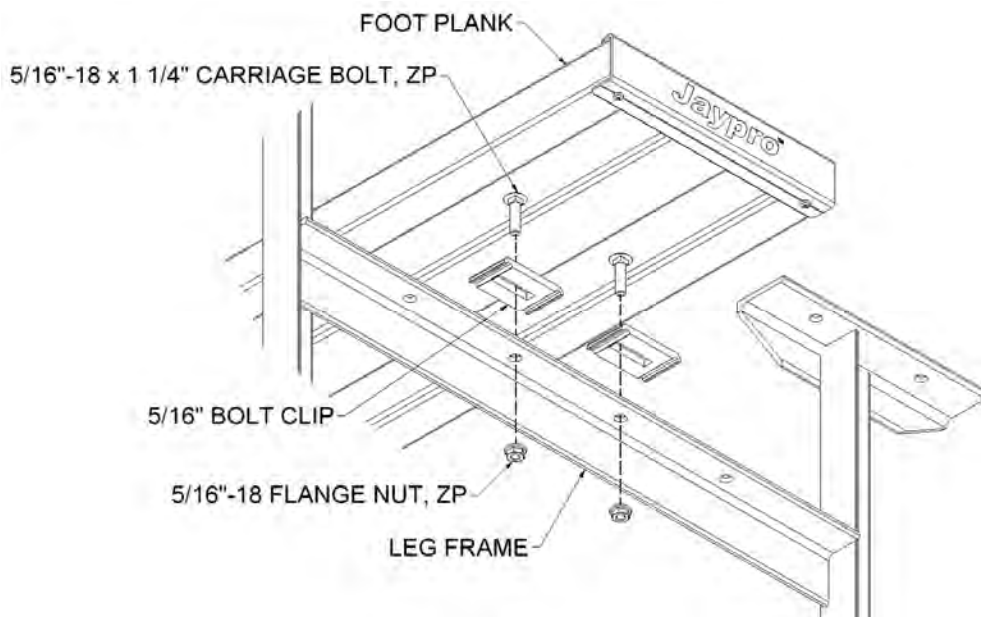

FIGURE: 5
(SINGLE FOOT PLANK)

Final Adjustments:

- Checks to make sure the bleacher is properly aligned and square. Securely tightened all plank hardware.