

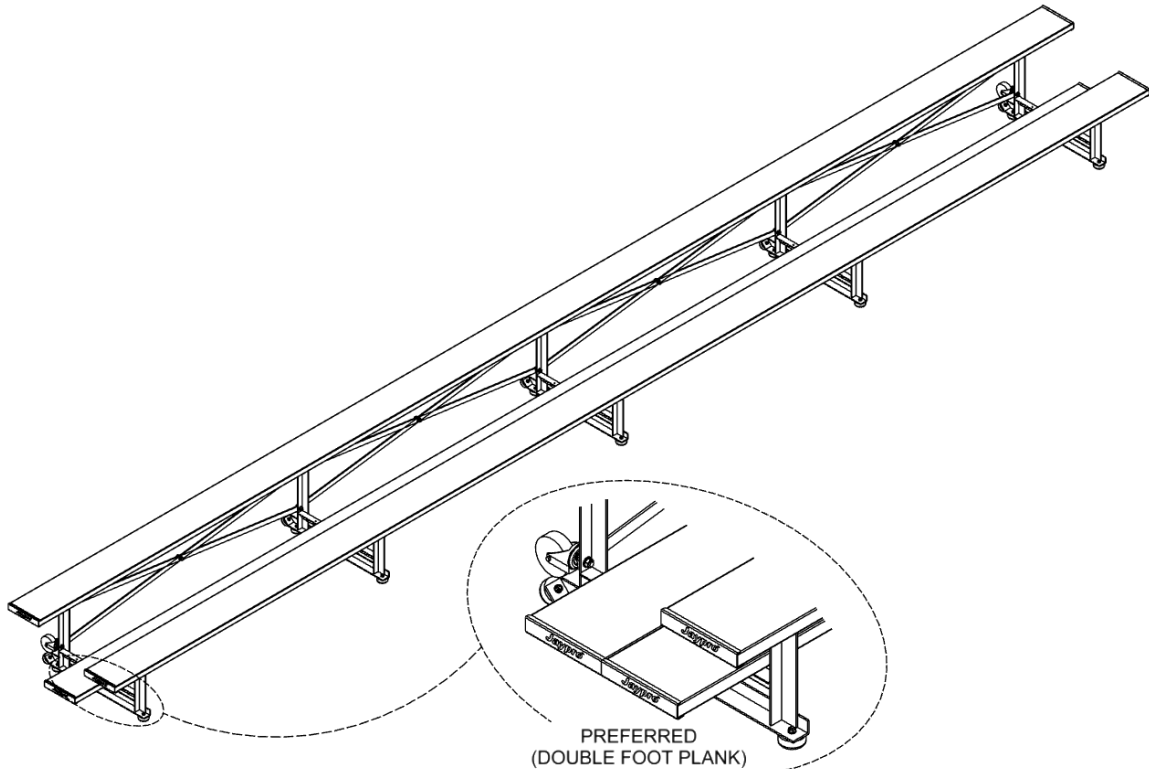

## -- 2 ROW, 27 FT ALUMINUM BLEACHER -- (STANDARD & PREFERRED TIP n' ROLL) Installation Instructions

BLCH-227TRG → Standard Aluminum 2 Row, 27 Ft Tip N' Roll Bleacher.

BLDP-227TRG → Preferred 2 Row, 27 Ft Tip N' Roll Bleacher, w/ Double Planks.



Call Jaypro Sports Equipment at 1-800-243-0533  
during regular business hours for technical support.

[www.jaypro.com](http://www.jaypro.com)

## JAYPRO SPORTS

### 2 ROW, 27 FT ALUMINUM TIP n' ROLL BLEACHER PARTS LIST

| ITEM | PART #     | DESCRIPTION                                    | BLCH-227TRG | BLDP-227TRG |
|------|------------|--|-------------|-------------|
| 1    | BLAL-2RL   | ALUMINUM 2-ROW BLEACHER LEG                    | 5           | 5           |
| 2    | BLAL-3RX-1 | 1/4" x 1-1/4" FLAT X-BARS (BLAL-321RX)         | 8           | 8           |
| 3    | AR5111     | 9-1/2" x 1-1/2" x 27' STADIUM PLANK            | 3           | 4           |
| 4    | CS0011     | 1/2"-13 x 1-1/2" THREAD x 4" DIA. CASTER WHEEL | 4           | 4           |
| 5    | RR5005     | RUBBER BUMPER                                  | 15          | 15          |
| 6    | HN5038     | 1/2"-13 FLANGE NUT                             | 18          | 18          |
| 7    | HW2050     | 3/8" FLAT WASHER, ZP                           | 15          | 15          |
| 8    | HS287      | 3/8"-16 x 1-1/4" HEX HEAD CAP SCREW, ZP        | 15          | 15          |
| 9    | HN5042     | 3/8"-16 FLANGE HEX NUT, ZP                     | 15          | 15          |
| 10   | HB5054     | 5/16"-18 x 1-1/4" CARRIAGE BOLT, ZP            | 30          | 40          |
| 11   | HN5046     | 5/16"-18 FLANGE NUT, ZP                        | 30          | 40          |
| 12   | AR5044     | 5/16" BOLT CLIP                                | 30          | 40          |
| 13   | HS5035     | #8 x 1/2" PAN HEAD PHILIP SCREW SELF DRILL, ZP | 12          | 16          |
| 14   | AR5045A    | 9-1/2" ALUMINUM SEAT PLANK END CAP             | 6           | 8           |
| 15   | HW2044     | 1/2" FLAT WASHER                               | 10          | 10          |
| 16   | HS2884     | 1/2"-13 x 1-1/2" HX HD CAP SC, ZP              | 10          | 10          |
|      |            |  | Kit # →     | BLTR-227RK  |
|      |            |  | Box # →     | 1           |
|      |            |  |             | BLDP-227RK  |
|      |            |  |             | 1           |

**IMPORTANT NOTICE:**

- 1) BEFORE EACH USE CHECK EQUIPMENT FOR PROPER CONNECTING HARDWARE AND STRUCTURAL INTEGRITY. REPLACE DAMAGED OR MISSING HARDWARE IMMEDIATELY.
- 2) USE OF THIS EQUIPMENT OTHER THAN INTENDED, MAY BE HAZARDOUS.
- 3) ALTERATION OR MODIFICATION OF THIS EQUIPMENT MAY BE HAZARDOUS AND RESULT IN INJURY. FOR REPAIR OR REPLACEMENT, CONTACT YOUR DEALER OR JAYPRO SPORTS.

## ASSEMBLY INSTRUCTIONS

### TOOLS REQUIRED:

- (1) 9/16" Socket Wrench and Box Wrench
- (1) 3/4" Socket Wrench and Box Wrench
- (1) Rubber Mallet
- (1) Phillips head screwdriver

- Unpack all parts and check against parts list to ensure that all have been included.
- Inspect all parts for damage. Report any damages to the trucking company.

### Install Feet and Wheel Casters:

1. Attach three rubber feet (bumpers) on the bottom of each leg as shown in figure 1.
2. Install two wheel casters & support braces on the backside of two leg frame as shown in figure 2 - fully thread caster stem on, but tighten only finger tight.

Note: The flange of each flange nut should be against the frame member.

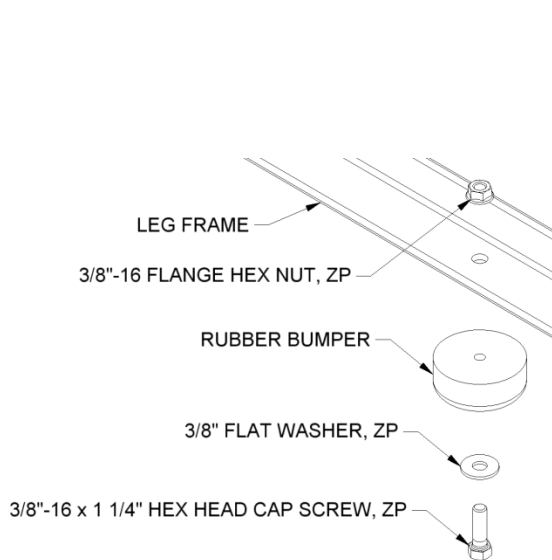

FIGURE: 1

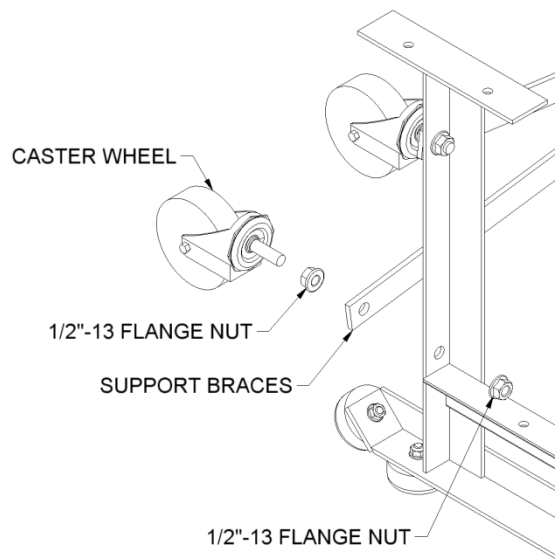

FIGURE: 2

**Assemble Frame:**

3. Assemble undercarriage frame as shown in figure 3. Vertically plumb and square each leg before tightening cross-bracing hardware.

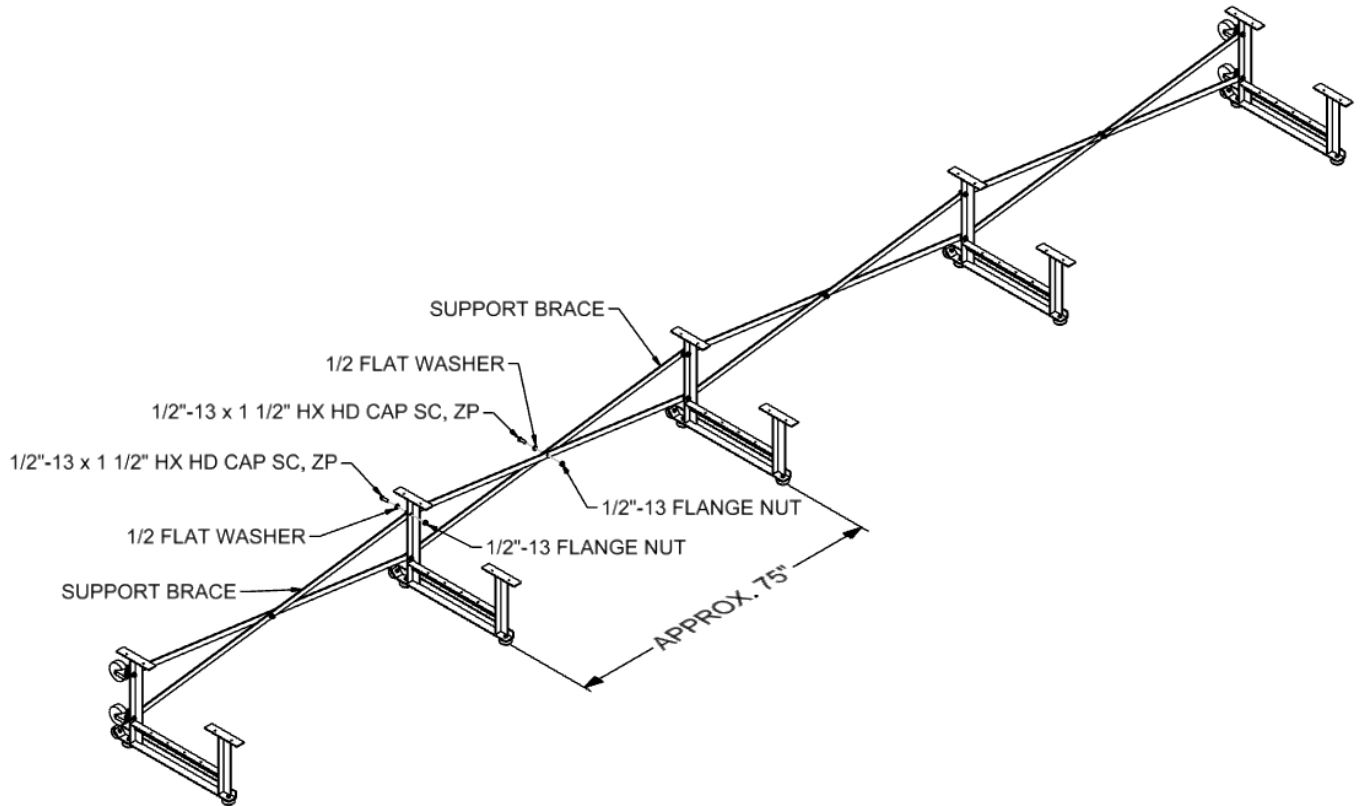

FIGURE: 3

**Install Seat and Foot Planks:**

4. Install end caps on both ends of each plank as shown in figure 4 – lightly tap on with a rubber mallet if necessary. Secure end caps in place using the #8 pan head self-drilling screws.

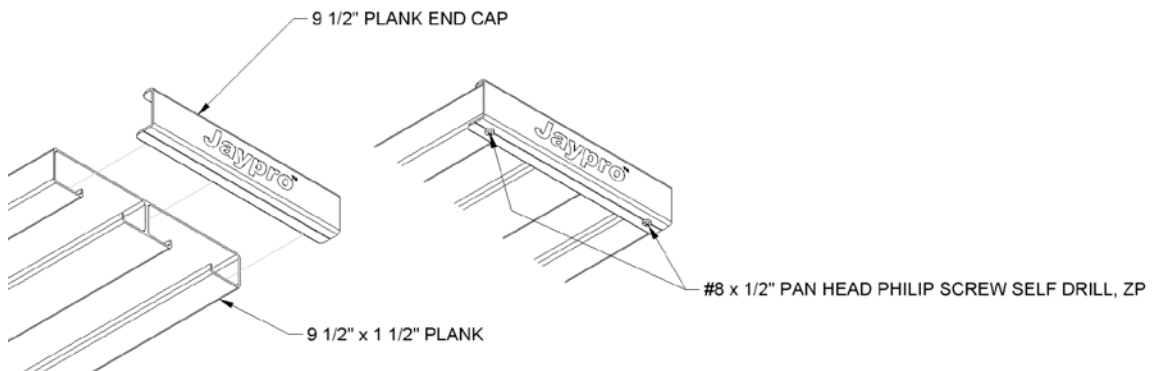

FIGURE: 4

5. Making sure the undercarriage frame is square and plumb, install the seat and foot planks. The seat and foot planks are best installed starting from the front seat and working towards the back. Use the hardware and bolt clip as shown in figure 5. Position planks so they are centered on the frame, with equal amount of overhang on each end. Note that standard bleacher (BLCH-227TRG) have a single foot plank, which is centered on the support frame, see figure 6. Preferred bleacher (BLDP-227TRG) have double foot planks and are installed as shown in figure 7.

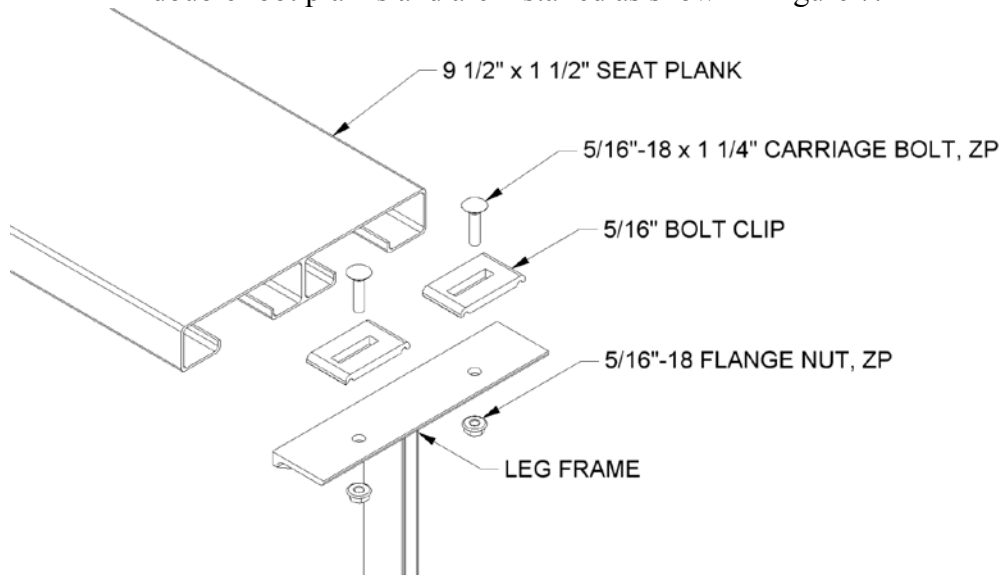

FIGURE: 5

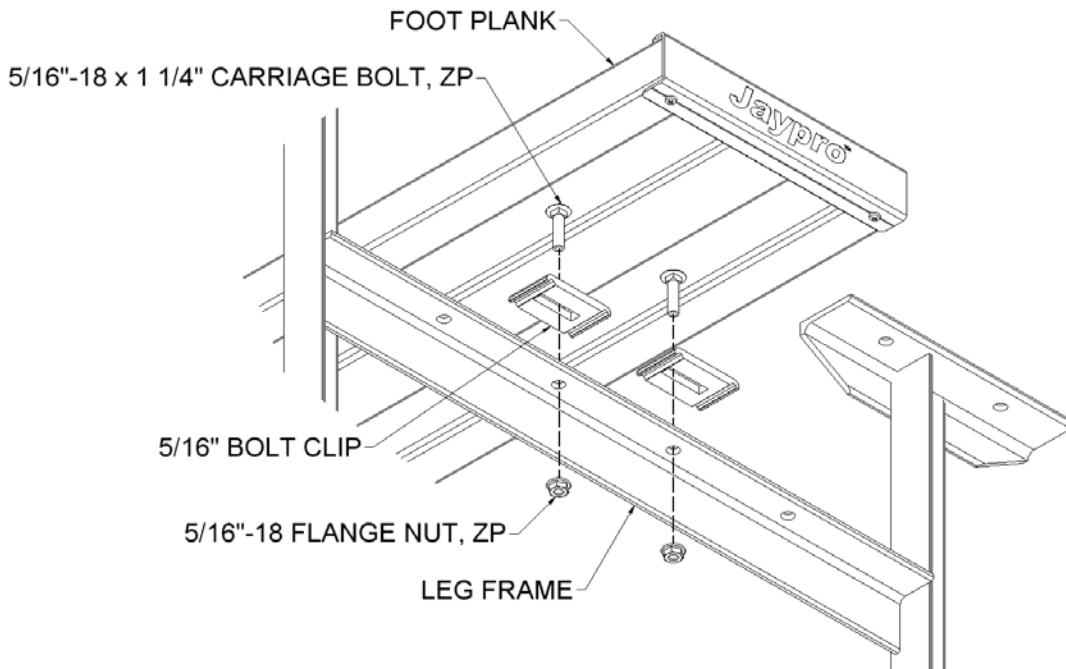

FIGURE: 6  
(SINGLE FOOT PLANK)

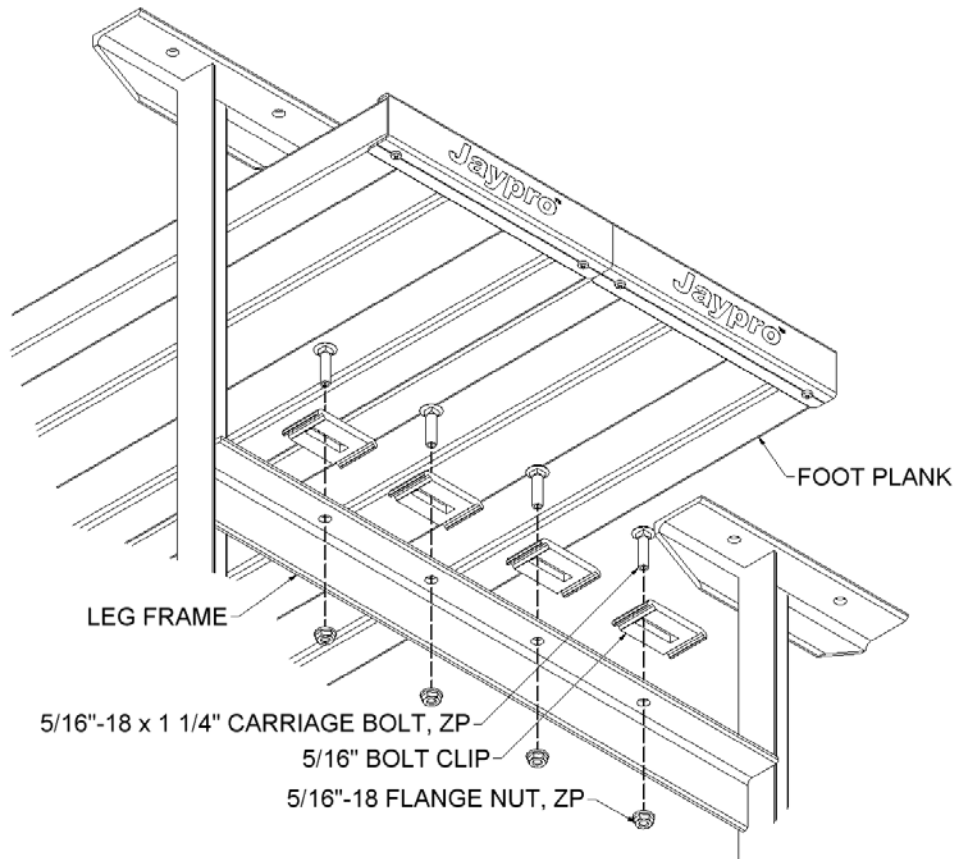

FIGURE: 7  
(DOUBLE FOOT PLANK)

**Final Adjustments:**

- Checks to make sure the bleacher is properly aligned and square. Securely tightened all plank hardware.
- Tip N' Roll bleachers: using two people stand the bleacher up on the wheel casters. Adjust the wheel height up/down so all the wheels are in equal contact with the floor. Securely tighten both nuts on each wheel caster.