

# GBA-342A ADJUSTABLE BREAKAWAY GOAL

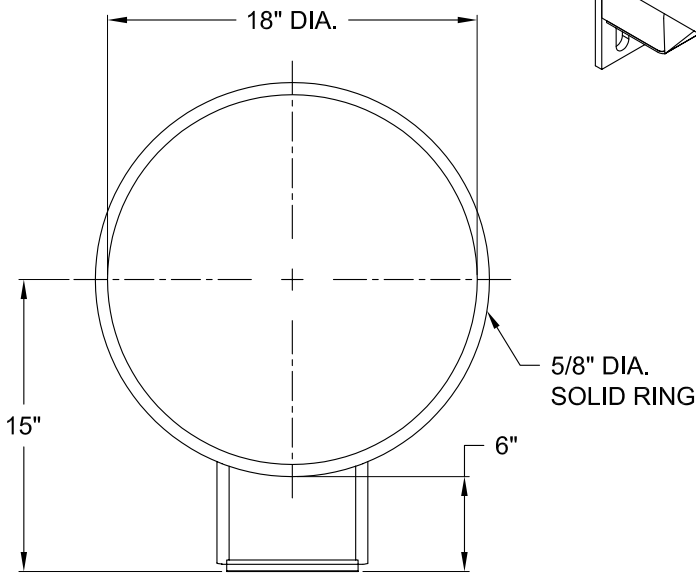

TOP VIEW

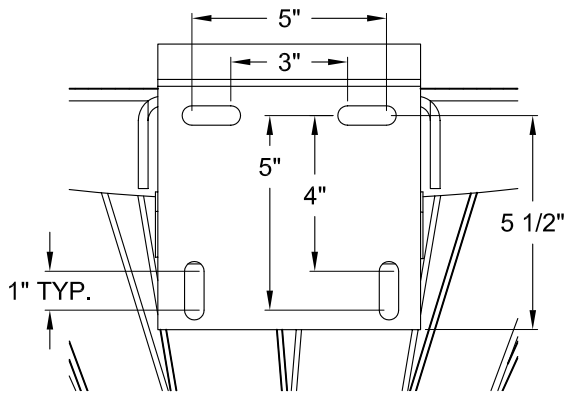
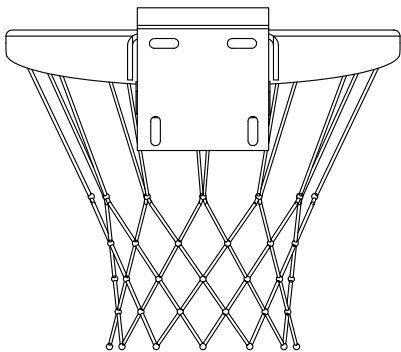
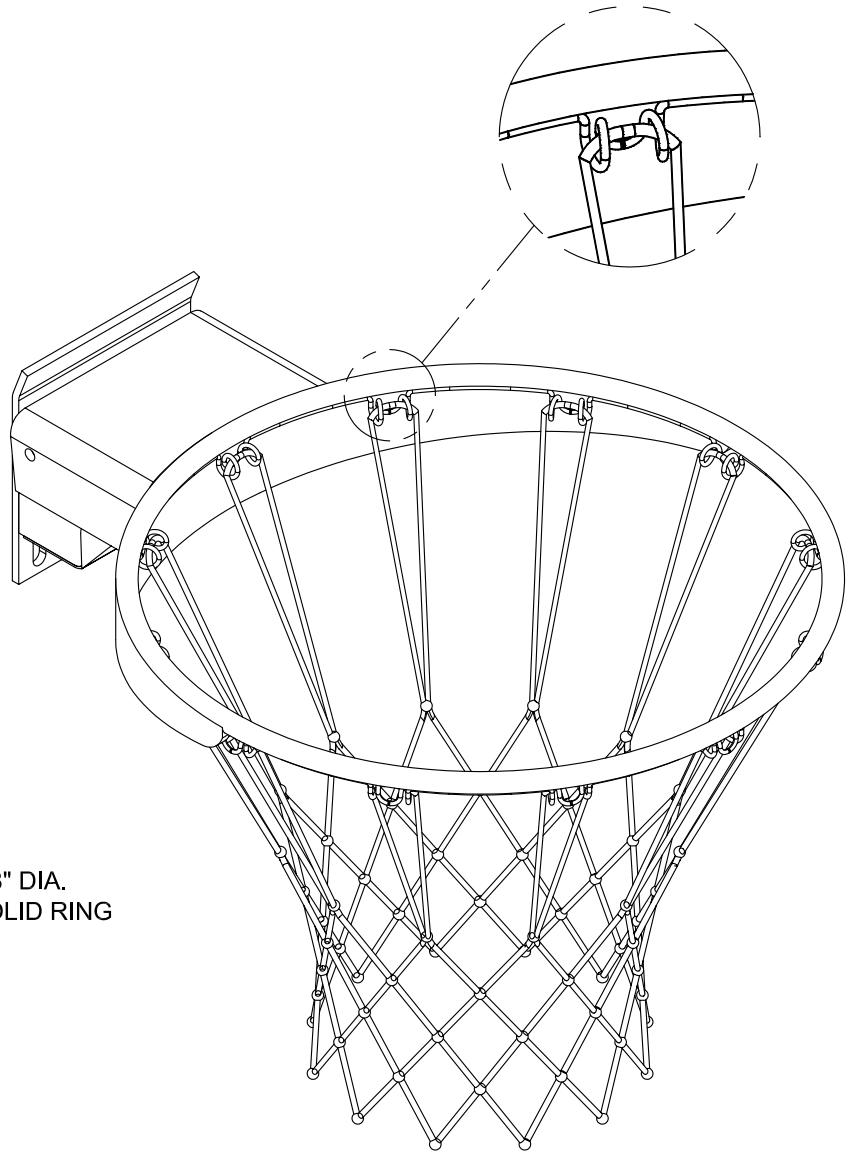

BACK VIEW

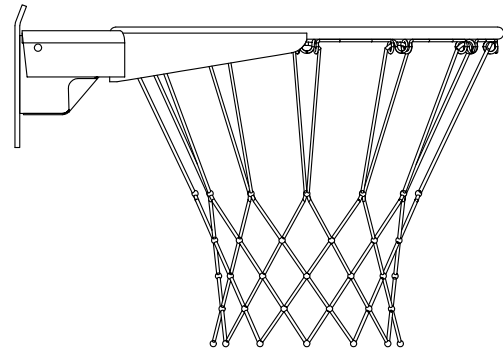

SIDE VIEW

REV.	DESCRIPTION	DATE	BY

**GBA-342A**  
**ADJUSTABLE BREAKAWAY**  
**GOAL**

THIS PRINT IS THE PROPERTY OF JAYPRO SPORTS, LLC.  
AND MAY NOT BE REPRODUCED WITHOUT WRITTEN PERMISSION



www.jaypro.com  
976 HARTFORD TURNPIKE  
WATERFORD, CT 06385 USA

DRAWING NAME / PART NO.: <b>GBA-342A</b>	
DRAWN BY: <b>RJR</b>	CHK'D BY: <b>DEM</b>
ISSUE DATE: <b>01/19/2006</b>	
SHEET: <b>1 OF 1</b>	REV.

COPYRIGHT 2006  
JAYPRO SPORTS, LLC.  
ALL RIGHTS RESERVED

# **GBA-342A**

## **ADJUSTABLE BREAKAWAY BASKETBALL GOAL**

Official Basketball Goal is manufactured to meet all NBA, WNBA, NCAA and NFHS regulations. 18" inside diameter ring is manufactured out of 5/8" diameter steel rod. Bracing of the ring is by 3/16" die cut steel brace welded to the underside of the ring. 12 net attachment loops are also welded to the underside of the ring to secure the anti-whip net (included) to the ring. The ring shall be attached to a positive lock pressure release mechanism that allows the ring to release when someone "slam dunks" the ball or hangs on the ring. This mechanism also absorbs the energy associated with those actions. The goal is pre-set to 180lbs-230lbs. The mechanism is completely field adjustable and can be set to provide rebound characteristics that are the identical characteristics of non-movable rings per the latest NCAA recommendations.

The attachment mechanism shall position the inside of the ring 6" from the face of the backboard. The complete goal shall be finished in a durable orange finish. Complete with mounting hardware, the GBA-342A incorporates a mounting plate that adapts to the majority of backboards sold.

The goal shall be warranted for a period of three years.