



## --- Jaypro Retractable Practice Cages --- Installation and Operating Instructions

### Applicable Jaypro Part Numbers / Cage Models:

**BBC-700B** = Ceiling Suspended Retractable Baseball Batting Cage

**BBC-700M** = Ceiling Suspended Retractable Multi Sport Cage

**BBC-UBKIT** = Installation Kit A – Direct Attached

**BBC-UP5KIT** = Installation Kit B – Spanning Parallel  $\leq 5'$

**BBC-KIT58** = Installation Kit C – Spanning Parallel  $>5'$  &  $\leq 8'$

**BBC-PERPKIT** = Installation Kit D – Spanning Perpendicular  $\leq 8'$

**BBC-RIGKIT** = Installation Kit E – Peaked or Rigid Frame Building



Figure 1: Jaypro BBC-700M Multi Sport Cage

## Important Notes

- Caution! This cage system is capable of lifting upwards of 1000 lbs of retractable cage frames and nets. However, injury and / or death can result if equipment is used in an unsafe manner.
- Do not lift more than one 12' x 70' cage.
- Follow all warning signs and labels on equipment.
- Inspect all equipment before each use. Do not operate equipment if any cables are frayed or bent, or any wires have been damaged.
- Make sure there are no obstructions above or below the cage frame or catch nets when operating the unit.
- Do not operate other moveable gym equipment (such as backstops, curtains, scoreboards, etc) close to the cage system at the same time as this unit is being operated.
- Do not leave the key in the wall switch. Only authorized personnel should have access to the keys.
- Always require that all personnel follow all safety procedures any time unit is in operation.
- Never use equipment for hoisting personnel or any other equipment besides that for which it was designed and tested.
- Should equipment become damaged or stop working as expected immediately stop using the system and tape off an area around the cage. Do not continue using until a qualified service technician has inspected the equipment and certified the system as safe to resume operating.
- Nets must be rolled tightly and stored on top of the frame. Do not operate unit with an off-balance load.
- Key switch must be located within clear eyesight of entire cage assembly. Never operate cage when sightline is obstructed. Post additional personnel around cage as needed to keep children and other unauthorized personnel clear from operating area.
- Facility personnel should never access the internal components of the winch.

- Only licensed electricians are permitted to provide power to the key switch, and to and from the winch. Authorized installation personnel may provide temporary wiring only for the purpose of testing equipment during the installation of the product.

Call Jaypro Sports Equipment at 1-800-243-0533 during regular business hours for any technical support questions or issues. Refer to Cage model number listed above when talking to customer service personnel.

[www.jaypro.com](http://www.jaypro.com)

## General Notes

- All components of the cage system have been fully tested at the factory to insure they are in proper working order. If for some reason the system does not work as expected after the installation has been completed, please review all steps in the procedure as well as the troubleshooting guide. If for some reason the system is still not functioning properly, you may call Jaypro directly at 1-800-243-0533.
- Only authorized and properly trained personnel should operate the cage. Operation of the cage should only be done while in clear view of the surrounding area. Always keep a copy of these operating instructions handy for anyone using the system. Jaypro recommends a policy of training and ‘signing off’ on instructions for anyone who will be tasked with operating the system.
- It is the ultimate responsibility of the person operating the cage system to insure that the unit does not become severely out of level. If for any reason the cage frame should exceed a 6” difference in elevation from one end to the other, **STOP OPERATING IMMEDIATELY!** Do not operate the system again until the problem has been diagnosed and repaired.
- Before operating cage system make sure all personnel are clear from the area
- Cage hoist is capable of holding one (1) 12’ X 70’ Frame and net. Net should be rolled evenly and stored as shown in images below during storage. Inspect cables regularly and order replacements at the first sign of wear.
- Key switch has two positions, Up and Down. Turn and hold key in direction of travel desired. Operator should always be observant of cage and surroundings during operation.
- Inspect cables and spools regularly. Order replacements at the first sign of frayed cable segments or any wear of metal parts.
- Listen for unusual sounds from hoist motor while the unit is being operated. Winches are somewhat loud normally, but if the noise they make should change over the period of their life then they should be inspected closely.

- Call Jaypro for pricing and scheduling of a field maintenance visit from one of our highly trained specialists if you are unwilling or unable to perform the regular maintenance yourself. Jaypro recommends that the Cage system be thoroughly inspected at least every year by a trained specialist. Call Jaypro or your dealer to arrange for servicing.

Jaypro Sports Equipment Phone #: 1-800-243-0533 Website: [www.jaypro.com](http://www.jaypro.com)

## Operating Instructions

### ***1. Key Switch Operation***

- a. Inserting the key and turning in the direction of travel actuates the key switch.
- b. Unit direction can be continually reversed without cause for concern with regards to system damage.

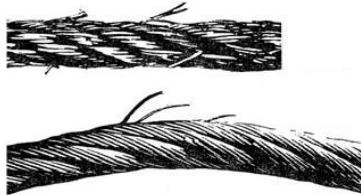
## Regular Equipment Maintenance

### ***1. Key Switch***

- a. Key switch is dual direction momentary actuated. No maintenance or upkeep should ever be required. For additional or replacement keys call Jaypro (you must have the key number).

### ***2. Wire Rope***

- a. Wire rope should be lubricated regularly to insure long reliable life. Obtain a suitable wire rope lubricant from local supply or hardware store. Do not use heavy grease or engine oil for lubricant. A recommended penetrating lubricant is MIL-G-18458 wire rope grease. Lubrication is best applied at the point of the wire rope bending over the pulley sheave, where the strands will be temporarily and partially separated allowing the lubricant to penetrate fully.
- b. Inspect rope for excessive damage or broken 'threads'. See image below – if wire rope looks like either of these pictures, it's time to replace it:



**Figure 2: Worn and Damaged Wire Ropes - Replacements Required**

- c. Replacement hoist cables (wire ropes) can be obtained directly from Jaypro, or from a qualified wire rope manufacturer or supplier. Cables are 1/8" x 7/19 Galvanized Cable with both ends terminated with a flemished eye splices and galvanized thimbles.

### ***3. Electric Hoists (Winches)***

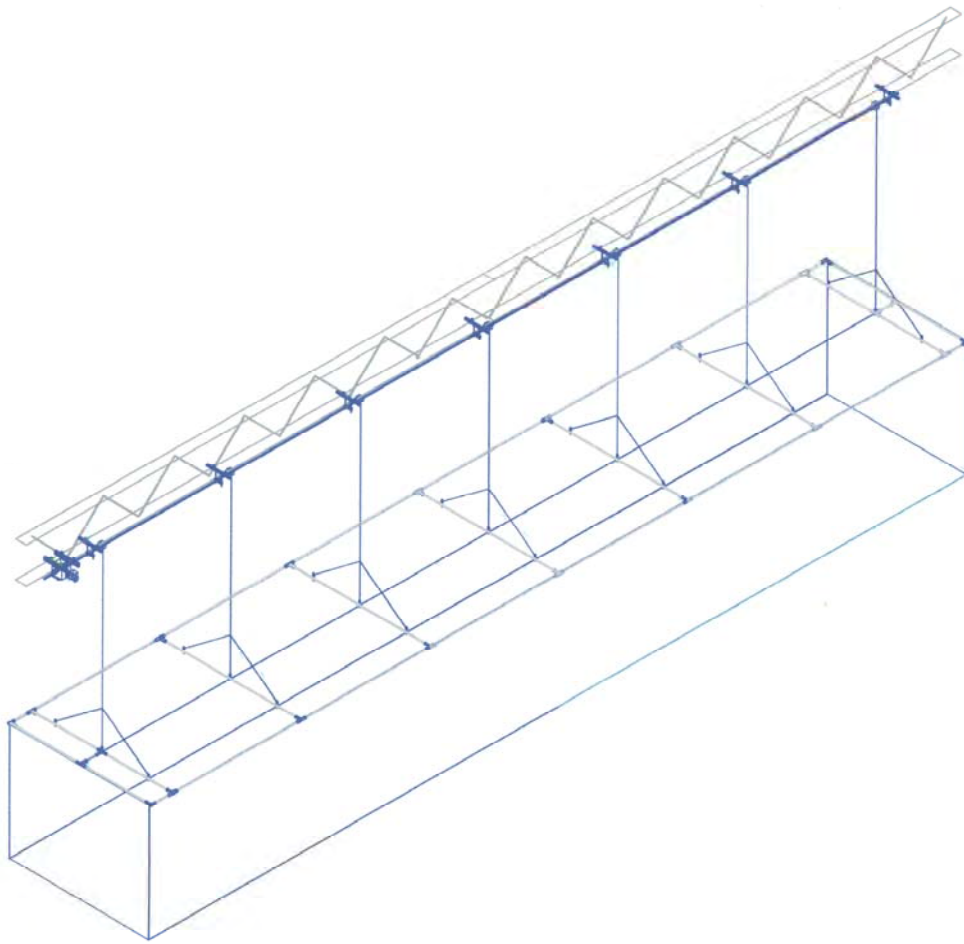
- a. Hoist is maintenance free and should provide years of repeated reliable service, barring damage from other equipment or electrical surge or other problem. Unit should, however, be inspected

regularly and if there is any sign of wear on the visible internal components a qualified service technician should be called in for further study.

- b. Inspect all attachment hardware for both the winch and the cable. Retighten or replace all hardware as necessary.

#### ***4. Service Plan & On-Site Maintenance Inspection***

- a. A thorough yearly inspection is recommended for entire system of hoists, cables, wiring, etc. If there are no qualified personnel on site who can do this work, it is recommended that you retain the services of a maintenance technician who is experienced with this type of equipment. You can research the availability of such a service locally or call Jaypro directly for a factory representative recommendation.



## **INSTALLATION PROCEDURES**

Important Note: The following installation procedures show the installation of a batting cage being directly attached to a single I-beam or bar joist, using the BBC-UBKIT mounting kit. Alternate mounting kits are available to attach cages between bar joists (BBC-UP5KIT, BBC-KIT58) and perpendicular to bar joists (BBC-PERPKIT). Although this document explains the steps in laying out the cage and drive assembly, refer to the individual mounting kit instructions for installing the support structure.

Only trained personnel, familiar with the use of common power tools, should attempt to install the batting cage and support structure.

### ***TOOLS REQUIRED:***

Standard Sockets.  
Open ended wrenches.  
Allen Wrench Set  
Screwdrivers  
Electric Drills  
Electric Saws  
Cable Cutters  
Measuring devises  
Levels and plumb bobs or lasers  
Lifts and or scaffolding  
Blocking wood  
Duct tape  
Thread Lock liquid  
5/16" Nut Drivers  
.

### ***SKILLS:***

Installation should be by persons with experience in indoor athletic equipment assembly.

- Contact Jaypro Sports for a recommendation of a certified installer in your area.

### ***UNPACKAGE AND VERIFICATION***

1. Verify that all your parts are accounted for
2. Verify that no parts were damaged in shipment.
3. Layout all parts and identify for assembly
4. The winch should be unpackaged and ground tested at this point.
  - The lower limit should be set and the drum turned until it rests at the lower limit position to aid in installation .
  - Reference the Winch documentation located within the winch box.

## ***ITEMS AND COUNTS***

<b>PACKAGE 1</b>	<b>TW-1200X-3C</b>	
	(1) TW-1200X-3C	WINCH
	(1) KS-13	KEY SWICH
<b>PACKAGE 2</b>	<b>BBC-700DT</b>	
	(7) DRIVEPIPE-B	2-3/8" OD GALV TUBES 135.75"
<b>PACKAGE 3</b>	<b>BBC-700DMK</b>	
	(6) HS292	3/8-16 X 3" HX HD BOLT
	(6) HN265	3/8-16 NYLON LOCK NUT
	(18) HM6134	1/2-13 CHANNEL NUT
	(18) HM6135	1-5/8 SQ STRUT WASHER W/ 9/16" HOLE
	(26) HN5038	1/2-13 FLANGE NUT
	(2) HS5040	1/2-13 X 4" HX HD BOLT
	(2) HN2951	1/2-13 NYLON LOCK NUT
	(4) HW2044	1/2 FLAT WASHER
	(14) HN5016	1/2-13 X 1-3/4" COUPLING NUT
	(14) HW1245	1/2 SPLIT RING LOCK WASHER
	(14) HN269	1/2-13 HX NUT
	(28) HS5091	5/16-18 X 1/2" SET SCREW
	(4) SR5187	1/2-13 X 12" THREAD ROD
	(14) SR5276	1/2-13 X 18" THREAD ROD
	(7) DPC-2	DRIVE PIPE CARRIER ASSEMBLY
	(14) CG-6	6" CABLE GUIDE FITTING
<p>*Hardware in PACKAGE 3 will vary for BBC-RIGKIT (See BBC-RIGKIT support drawing package for detail parts list.)</p>		
<b>PACKAGE 4</b>	<b>BBC-700CK</b>	
	(1) NW0048	3/4" X 25 YDS BLACK VELCRO 'ONE WRAP
	(35) HM403	1/8" WIRE ROPE CABLE CLAMP
	(21) HM6169	1/8" WIRE ROPE CABLE THIMBLE
	(21) HB5048	3/8-16 X 5" EYE BOLT
	(42) HW2050	3/8 FLAT WASHER
	(21) HN265	3/8-16 NYLON LOCK NUT
	(124) HS5144	#10 X 1" RND WASHER HD PHILLIPS SCREW
	(7) RC5017-14	1/8" AIRCRAFT CABLE 7X19 GALVANIZED 14'
	(7) RC5017-40	1/8" AIRCRAFT CABLE 7X19 GALVANIZED 40'
	(4) BBC-EL	CAGE ELBOW FITTING
	(18) BBC-T	CAGE T FITTING
<b>PACKAGE 5 &amp; 6</b>	<b>BBC-700CP &amp; BBC-700CP-1</b>	
	(2) AP5008-20	1.90 OD ALUM TUBE 20"
	(9) BBC-PIPE-A	1.90 OD ALUM TUBE 144" W/ 3 HOLES
	(4) AP5008-288	1.90 OD ALUM TUBE 288"
	(2) AP5008-264	1.90 OD ALUM TUBE 264"

**PACKAGE 7****BBC-700M**

(1) BBC-700M

12' X 10' X 70' TUNNEL #252 3/4" SQ NETTING

**CAGE SUPPORT KITS (Contains Attachment Kit and Support Structure)****BBC-UBKIT (Direct Attached) Purchased Separately**

(9)	SR5239-36	1 5/8 x 1 5/8 x 36 in SINGLE STRUT CHANNEL
(18)	HM6157	SINGLE STRUT BEAM CLAMP ASSEMBLY

**BBC-UP5KIT (Spanning Parallel 5 ft. or less) Purchased Separately**

(9)	SR5239-96	1 5/8 x 1 5/8 x 96 in SINGLE STRUT CHANNEL
(36)	HM6157	SINGLE STRUT BEAM CLAMP ASSEMBLY

**BBC-KIT58 (Spanning Parallel 5 ft. to 8 ft) Purchased Separately**

(9)	SR5243-120	1 5/8 x 3 1/4 x 120 in DOUBLE STRUT CHANNEL
(36)	HM6159	DOUBLE STRUT BEAM CLAMPS

**BBC-PERPKIT (Spanning Perpendicular) Purchased Separately**

(2)	SR5239-24	1 5/8 x 1 5/8 x 24 SINGLE STRUT CHANNEL
(8)	SR5243-240	1 5/8 x 3 1/4 x 240 in DOUBLE STRUT CHANNEL
(6)	HM6222	4 HOLE PLATE
(32)	HM6159	BEAM CLAMPS
(24)	HS5133	1/2 -13 x 1 1/4 in HEX HEAD CAP SCREW
(4)	HW2050	3/8 FLAT WASHER
(4)	HS 286	3/8-16 x 1 in HEX HEAD CAP SCREW
(4)	HM6158	3/8-16 STRUT NUT
(24)	HM6134	1/2 -13 STRUT NUT

**BBC-RIGKIT (Peaked or Rigid Frame Buildings) Purchased Separately**

(See BBC-RIGKIT support drawing package for detailed parts lists)

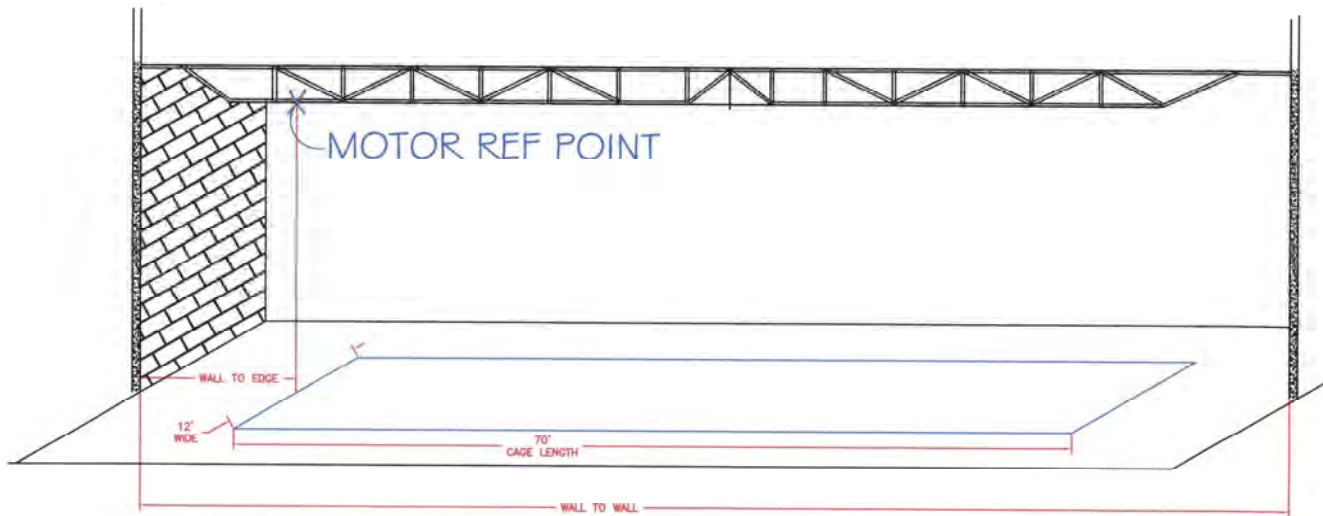
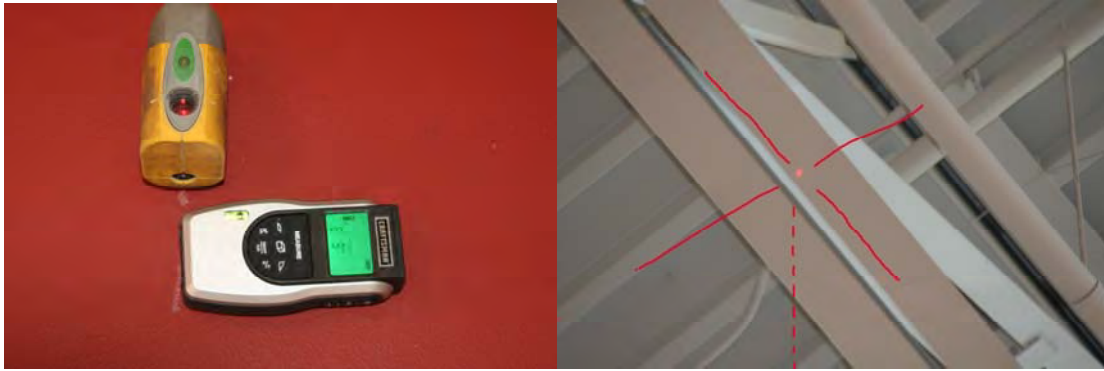
***MEASURE AND ESTABLISH LOCATION OF CAGE.***

1. The cage is 12' Wide by 70' long once assembled.
2. There should be a clear area around the perimeter of the cage that is 3' minimum.
3. The motor of the cage should be located outside the frame to allow for service to the motor in either the retracted or down position.

***ESTABLISH THE MOTOR REFERENCE POINT.***

1. The assembly of the cage and drive system is based on the establishment of a motor reference point.
2. The motor reference point is on the center line of the 12' side of the cage on either end of the cage frame.
3. The reference point must be transferred to the ceiling structure of the building to establish the attachment points for the motor and drive pipe carriers.
4. A plumb laser is the preferred method for achieving this location.

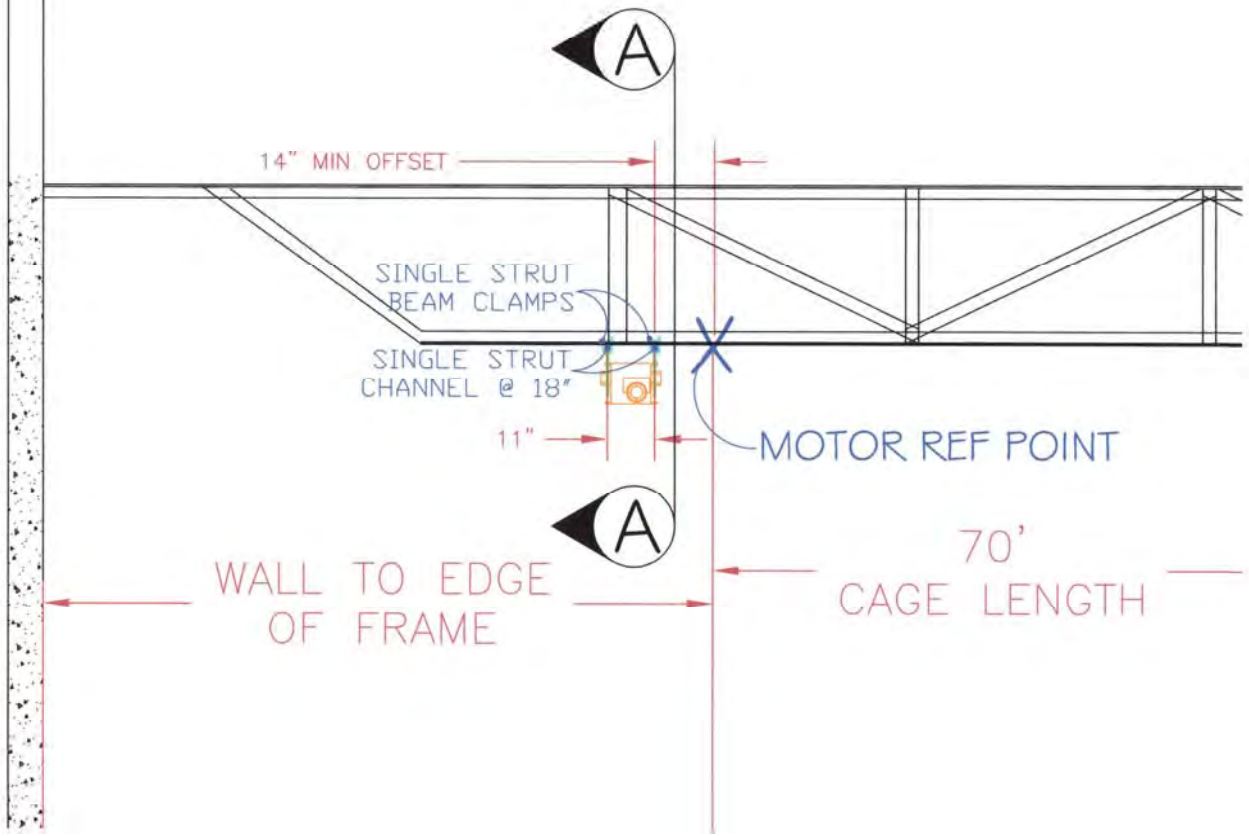




**FIGURE 1- MOTOR REFERENCE POINT**

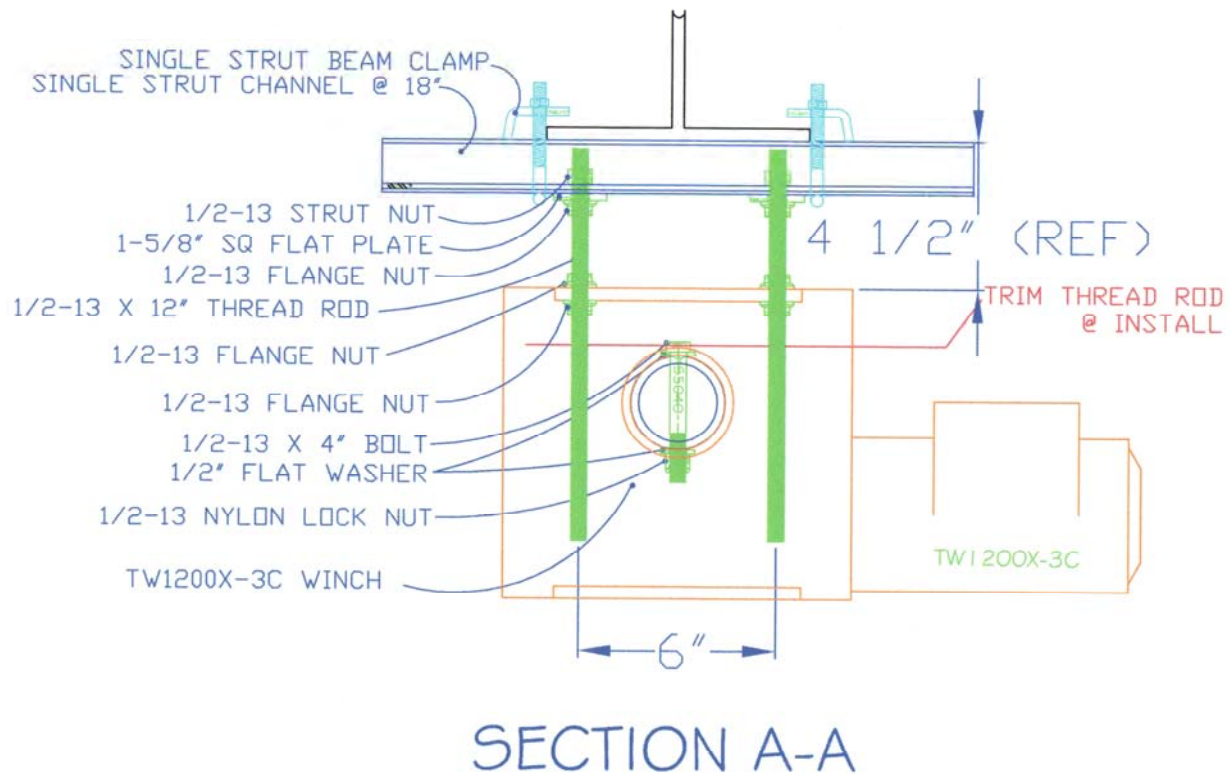
***INSTALL MOTOR ATTACHMENT STRUT AND MOTOR ASSEMBLY.***

1. 2 pieces of Unistrut that is 11" c/c are attached to the beam with unistrut clamps at a location of the first piece a minimum of 14" outside the frame perimeter away from the motor reference point.
2. Loosely assemble the motor assembly and hoist it into position.
3. Attach the motor assembly to the motor strut and establish the drive pipe centerline Above Finished Floor, (AFF).
4. Secure all nuts to mount the motor to the strut.
5. **DO NOT INSTALL** the winch drive bolts to the winch at this time.



**FIGURE 2 - MOTOR INSTALL**

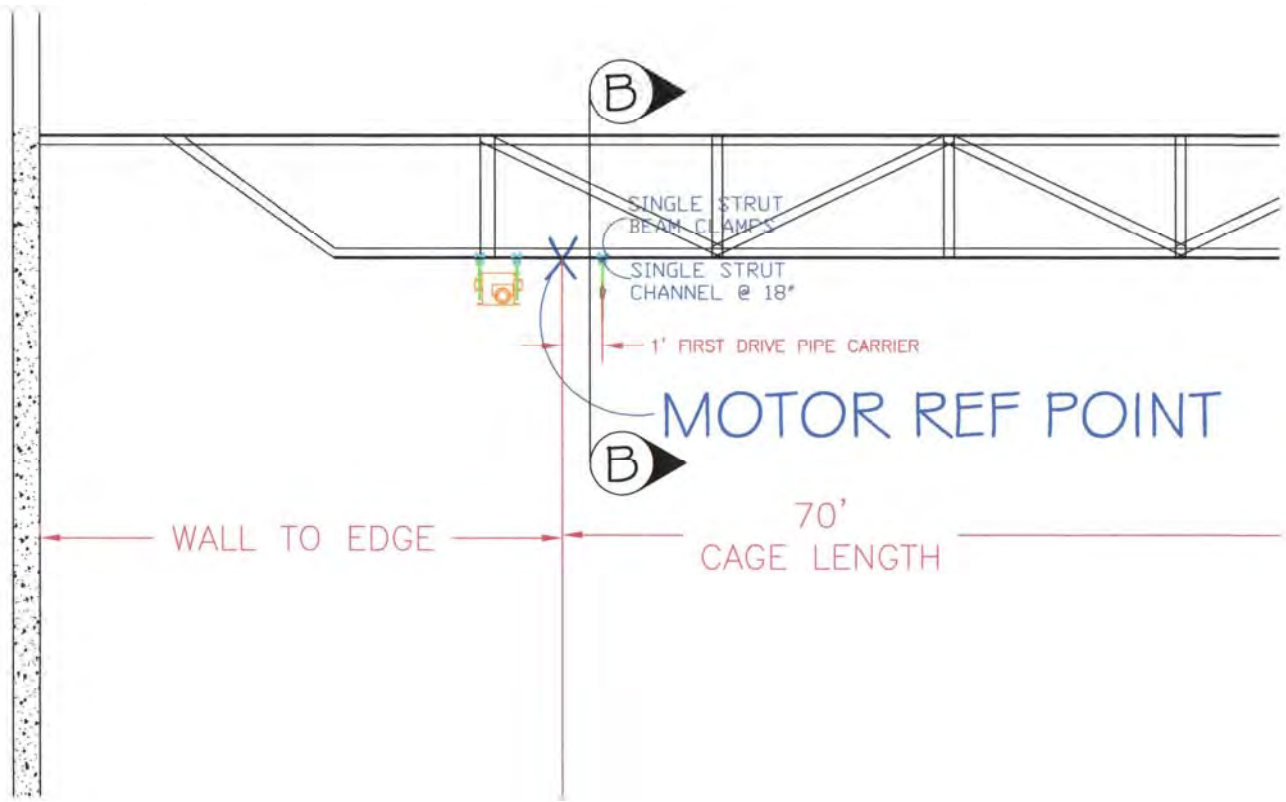




**FIGURE 3 - MOTOR ASSEMBLY**

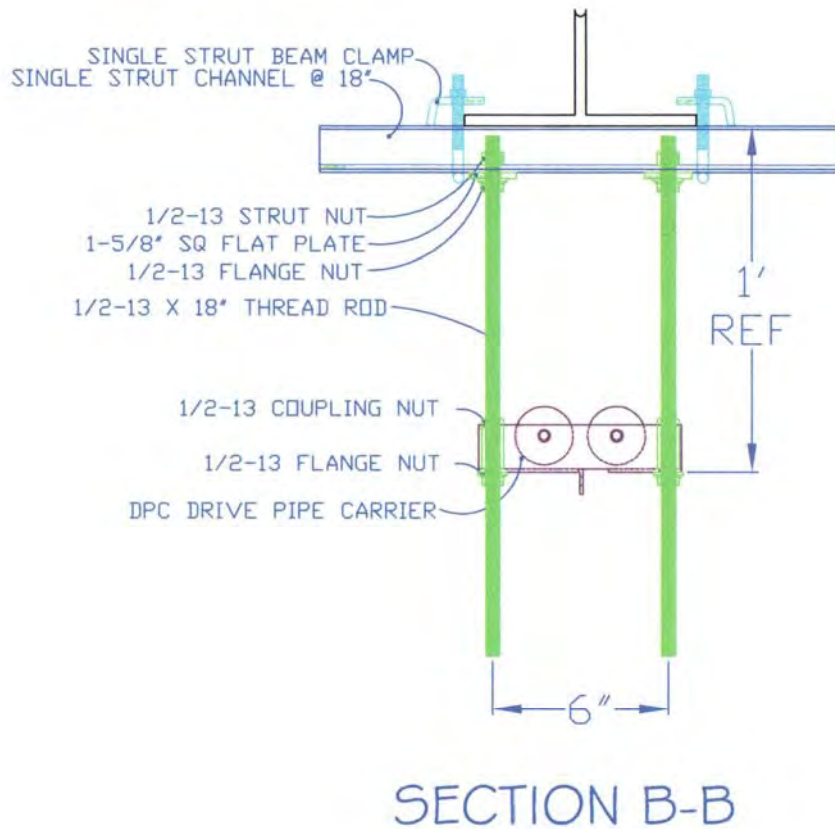
***INSTALL FIRST DRIVE PIPE CARRIER STRUT AND ASSEMBLY.***

1. The next attachment is that of the first Drive Pipe carrier assembly to unistrut that is located 1' from the motor reference point to be located within the perimeter of the cage.
2. Attach this piece of strut to the beam with unistrut beam clamps.
3. Attach a loosely assembled Drive Pipe Carrier Assembly, (DPC-A), to the strut.
4. Establish the required Drive Pipe Centerline AFF for the carrier.
5. Secure all nuts to mount the assembly to the strut.



**FIGURE 4 - FIRST DPC**

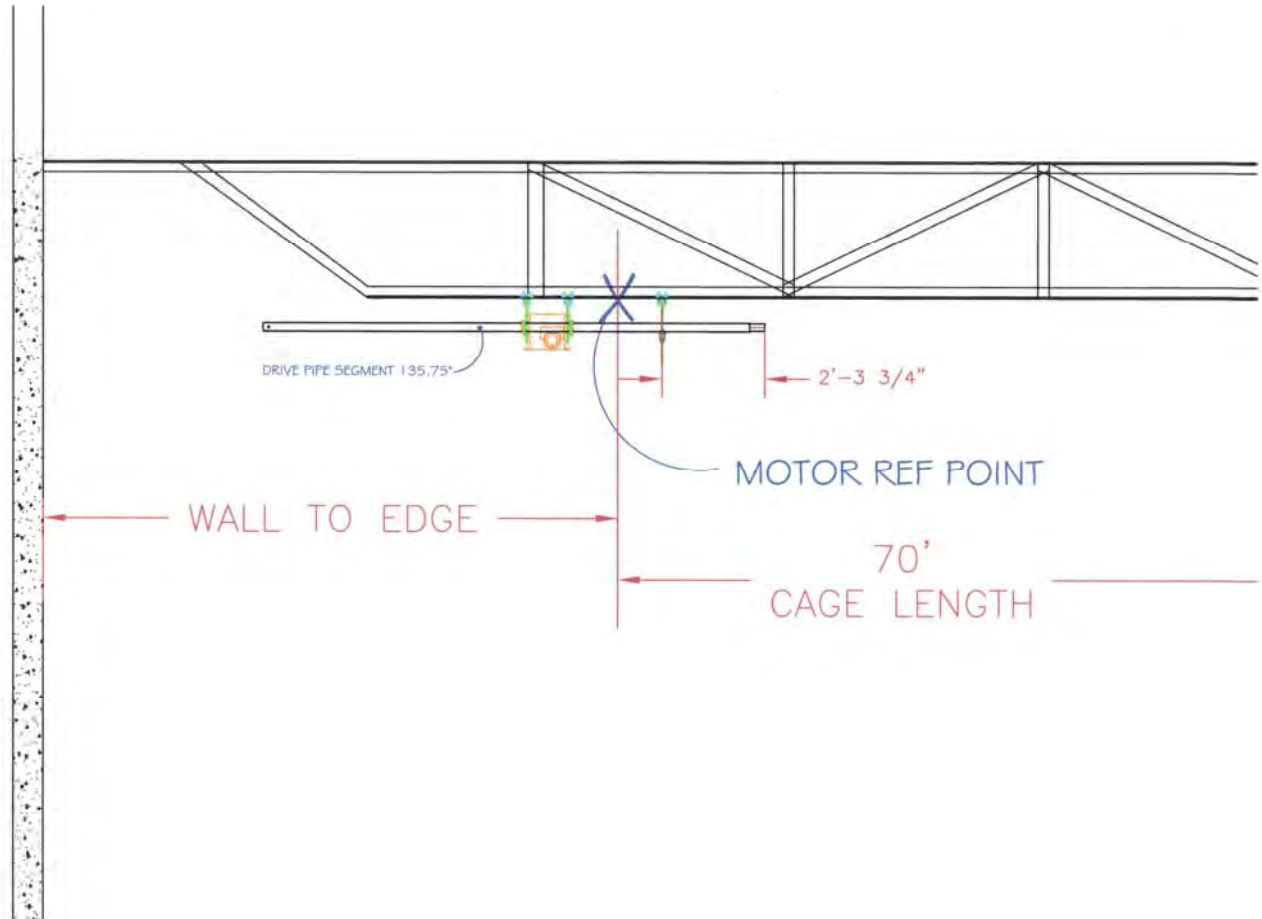




**FIGURE 5 - SECTION B-B**

***INSTALL THE FIRST SEGMENT OF DRIVE PIPE***

1. Insert the Swaged end of one section of drive pipe into the winch drum and push towards the first DCP-A.
  - Pipe may be inserted opposite direction if clearance is an issue.
2. Continue to insert the drive pipe segment through the DPC-A and continue the edge of the pipe to end 27-3/4" beyond the center of the DPC-A.
3. Temporarily secure the drive pipe section to the winch with Duct Tape to prevent it moving unexpectedly.



**FIGURE 6- DRIVE PIPE SEGMENT**

***INSTALL A PAIR OF CABLE GUIDES ONTO THE DRIVE PIPE.***

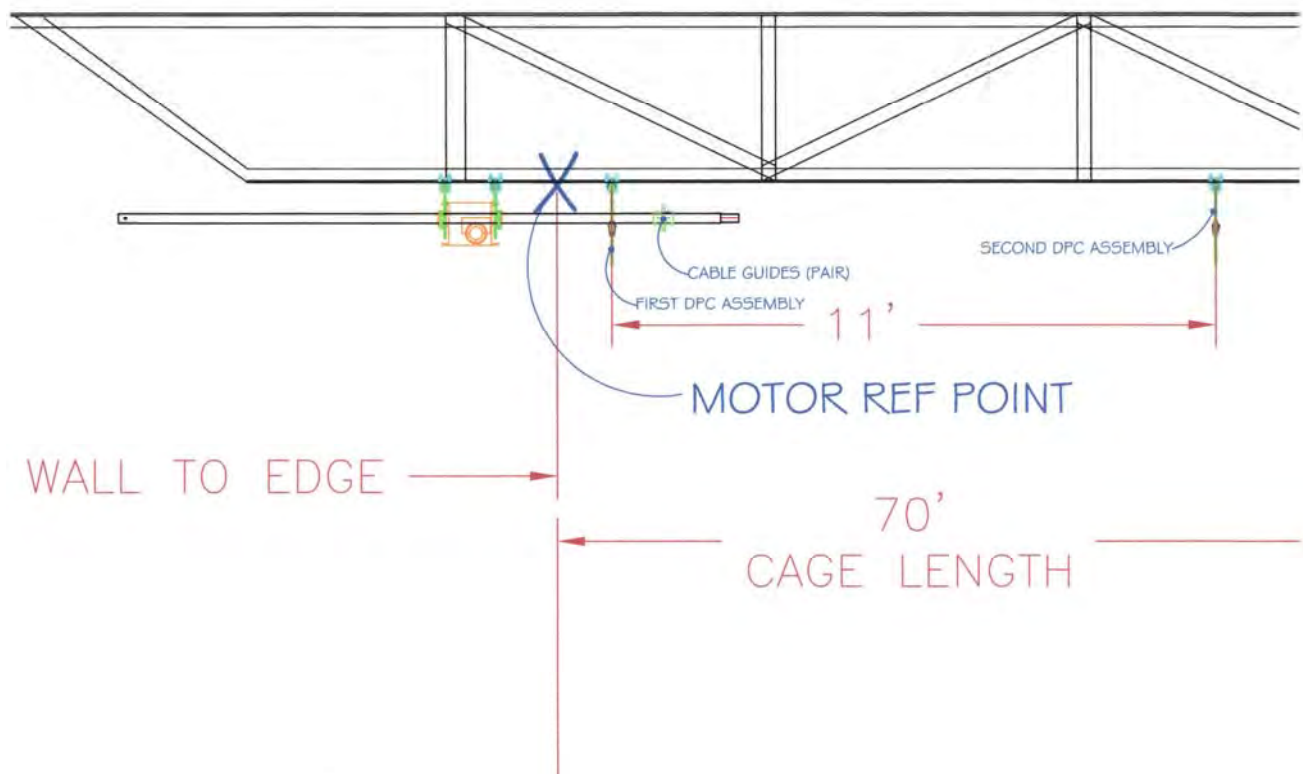
1. Slip a pair of cable guides on to the drive pipe.
2. Position the cable guides with the large discs next to each other.
3. **DO NOT** tighten these to the drive pipe at this point.





## ***INSTALL THE SECOND DRIVE PIPE CARRIER STRUT AND ASSEMBLY.***

1. You will continue to work away from the motor reference point.
2. The strut for the second drive pipe carrier is installed with strut beam clamps at a location that is 11' from the first drive pipe carrier location.
3. Loosely install a DPC-A to that strut and adjust for Drive Pipe Center line AFF.
4. Secure all nuts to mount the assembly to the strut.

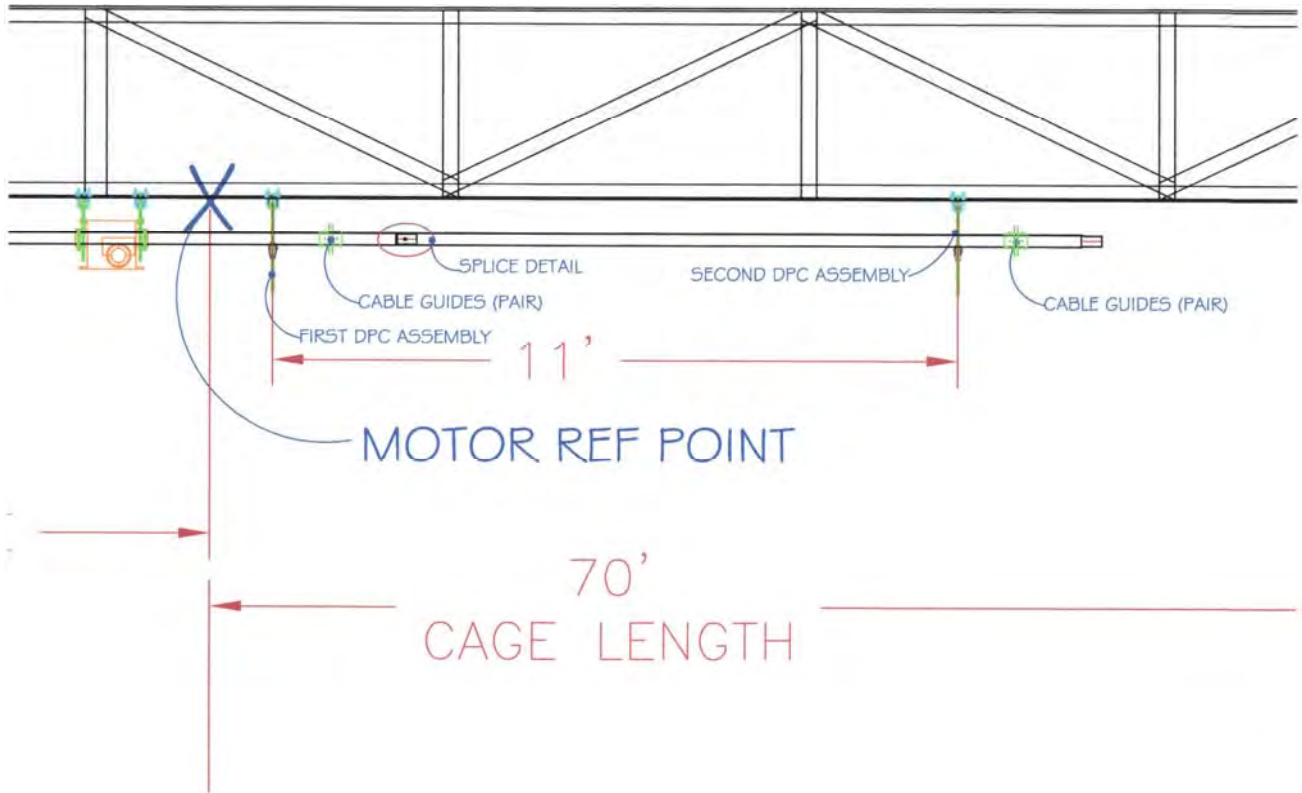


**FIGURE 7 - SECOND DPC**

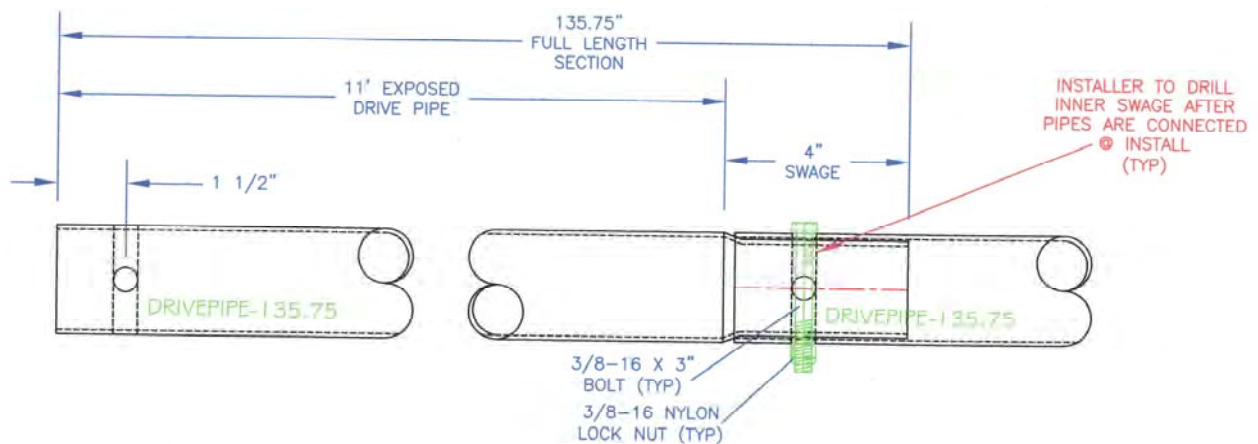
## ***INSTALL THE SECOND DRIVE PIPE SEGMENT TO THE FIRST DRIVE PIPE SEGMENT.***

- 1 Insert a drive pipe segment through the second DPC-A towards the first drive pipe segment.
- 2 Insert the drive pipe segment non-swaged end first through the second DPC-A.
- 3 Allow the non swaged end of Drive pipe segment 2 to go over the swaged end of drive pipe segment one.
- 4 Insert the second drive pipe fully over the swage of drive pipe 1 segment.
- 5 Splice the Drive Pipe segments together.

- i. Drill thru the swaged end of the first drive pipe segment by using the pre-drilled holes on the non swaged end of the second drive pipe as alignment.
- ii. Insert a 3/8" x 3" Bolt thru the hole and secure the pipes together with a 3/8-16 Nylon Lock Nut



**FIGURE 8 - SECOND DRIVE PIPE SEGMENT**



**FIGURE 9 - DRIVE PIPE SPLICE**





***INSTALL A PAIR OF CABLE GUIDES ONTO THE DRIVE PIPE.***

1. Slip a pair of cable guides on to the drive pipe.
2. Position the cable guides with the large discs next to each other.
3. DO NOT tighten these to the drive pipe at this point.

***CONTINUE DPC-A STRUT, ASSEMBLY, DRIVE PIPE SEGMENTS, SPLICES AND CABLE GUIDES FOR THE REMAINING PARTS.***

1. Assure that you are maintaining level drive pipe center line AFF throughout the process.
2. Each remaining DPC-A should be 11' from the last.

***VERIFY THAT THE DRIVE PIPE FULLY ASSEMBLED TURNS FREELY ALONG IT'S LENGTH.***

***SECURE THE DRIVE PIPE TO THE WINCH***

1. Drill through the drive pipe using the holes on the drive pipe collars.
2. Secure with ½-13 x 4" Bolts, washers and nylon lock nuts.



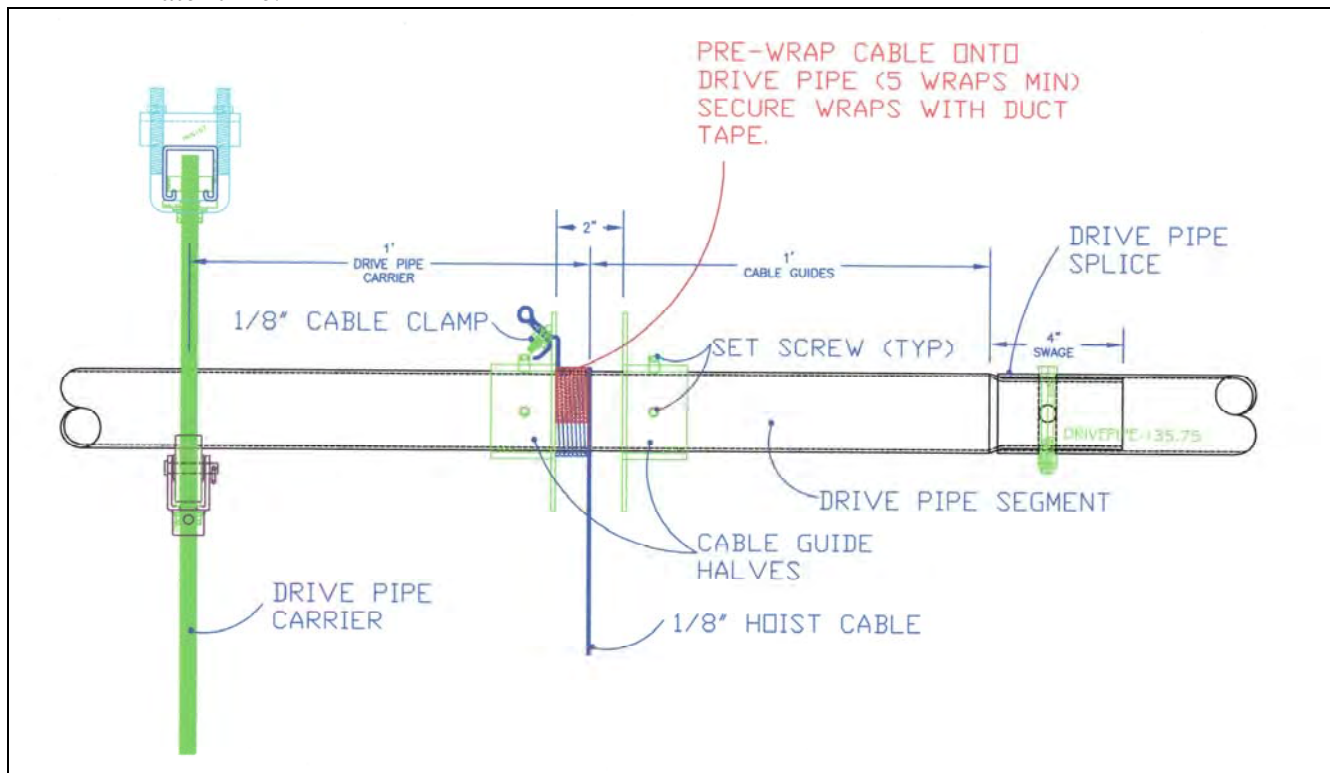
***CUT ANY EXCESS DRIVE PIPE FROM DRIVE PIPE SEGMENT ONE.***

1. Allow for a min of 8" exposure before cutting away excess.

## ***TRIM ANY EXCESS THREAD ROD THAT MAY EXIST.***

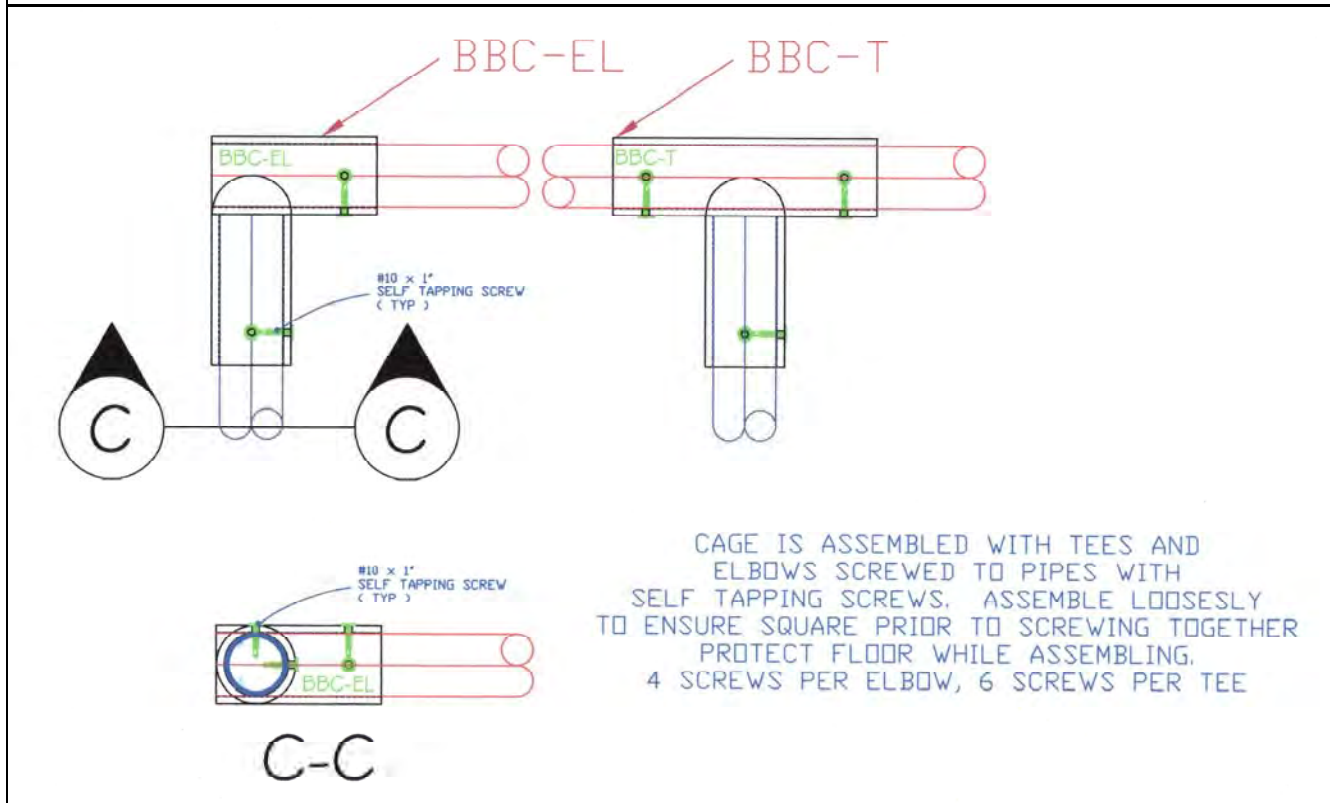
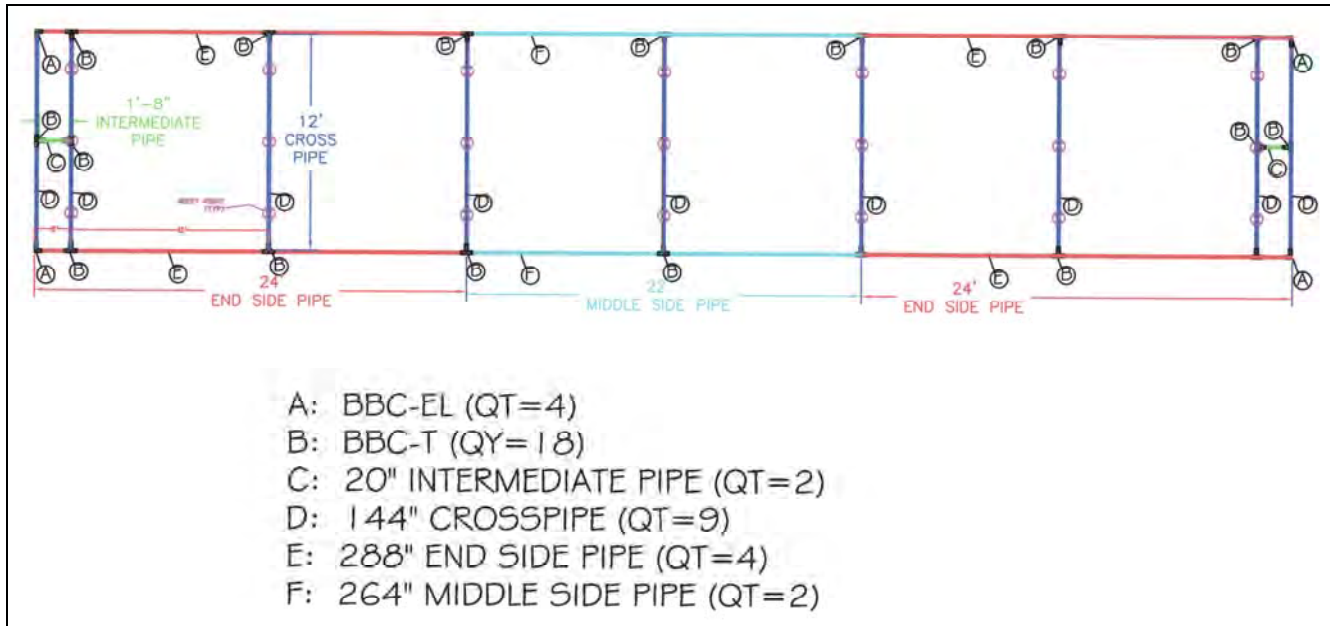
### ***POSITION AND SECURE THE CABLE GUIDE PAIRS AND HOIST CABLES.***

1. Each cable guide pair should be located between a drive pipe carrier and a drive pipe splice.
  - IT IS CRITICAL THAT THE GUIDES BE DIRECTLY ABOVE THE HOIST CABLE LOCATIONS. THE FIRST GUIDE IS 2' FROM THE FRAME EDGE AND SUBSEQUENT GUIDES ARE 11' C/C.
2. The cable guide pairs should be positioned to allow 2" of space between the discs.
3. The 2" space should be centered and is positioned 1' away from the nearest DPC-A.
4. Secure the Cable guides to the Drive pipe by tightening the 5/16 Set screws against the drive pipe.
5. Pre-wrap a hoist cable with a min of 5 wraps around the drive pipe and pass the top end of the cable through the hole in one side of the cable guide pair. Outside the 2" opening the cable should be secured to itself with the use of a cable clamp making a loop in the cable.
6. The cable clamp should be brought tight against the disc and all slack removed from the cable wraps on the drive pipe.
7. Align all the wraps together against the disc creating neat rows of cable.
8. Secure these rows to the drive pipe by placing duct tape over the rows to prevent them from moving.
9. Allow the remaining length of cable to drop to the floor for installation to the frame at a later time.



## ASSEMBLE THE CAGE FRAME.

1. Protect the floor of the building by inserting wood blocks under all frame segments and fittings. While drilling or screwing frame together, protect the floor where you are working with a scrap piece of plywood. This will protect the floor surface should a drill accidentally slip from it's intended direction.
2. Assemble in final position by aligning the motor reference point to the centerline of the cage's 12' on the ground.
3. Assemble all segments loosely until square is established, then screw together the segments.

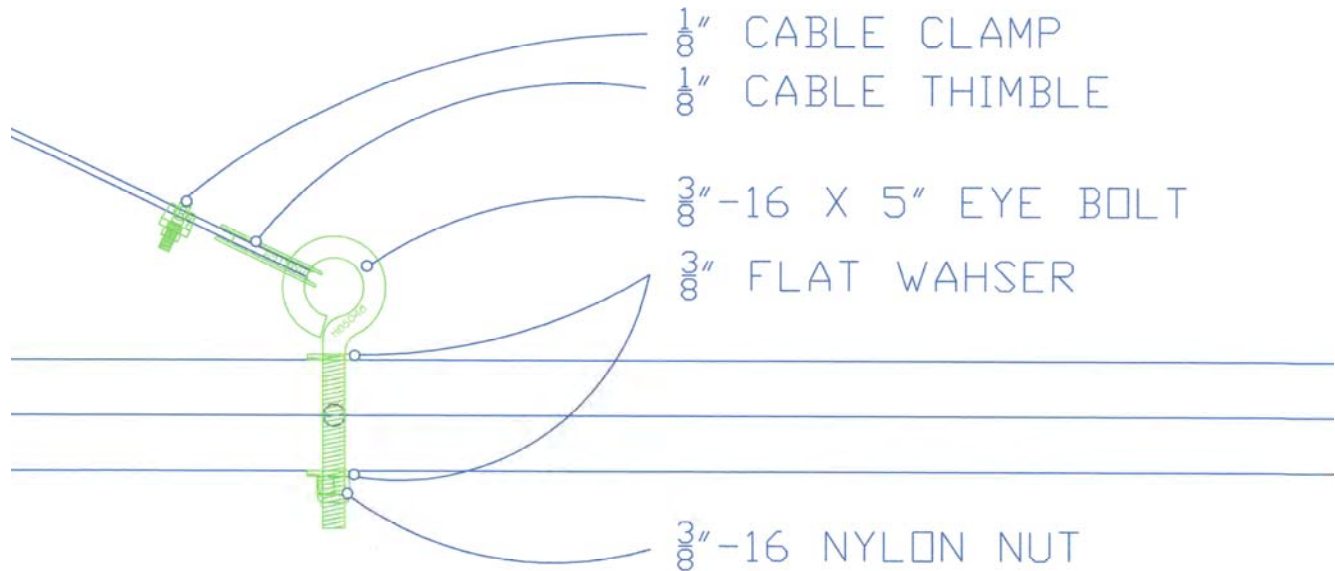


- Check that all burrs have been removed from the inside of the BBC-EL and BBC-T prior to assembly. These fitting should move freely on their pipes.

### **ATTACH THE ANCHORING EYE BOLTS TO THE FRAME AND SECURE**

1. There are 21 connection points on the cage
2. Each connection point is a 3/8" x 5" EYE Bolt with washers and a Nylon lock nut.
3. Note that you will be required to drill through the T fitting at the end hoist cable locations.

#### { TYPICAL CABLE ATTACHMENT }



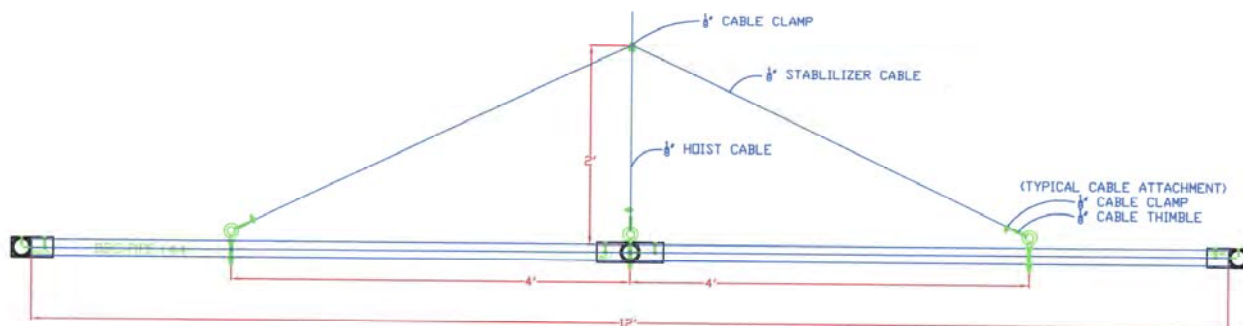
### **ATTACH THE HOIST CABLES TO THE CENTER EYE BOLTS.**

### **ATTACH THE STABILIZING CABLES TO THE OUTER EYEBOLTS**

1. VERIFY A CONSISTANT LENGTH OF THE STABILIZER CABLES
2. TAPE OFF THE ENDS OF THE CABLE

### **ATTACH THE STABLIZING CABLES TO THE HOIST CABLE**

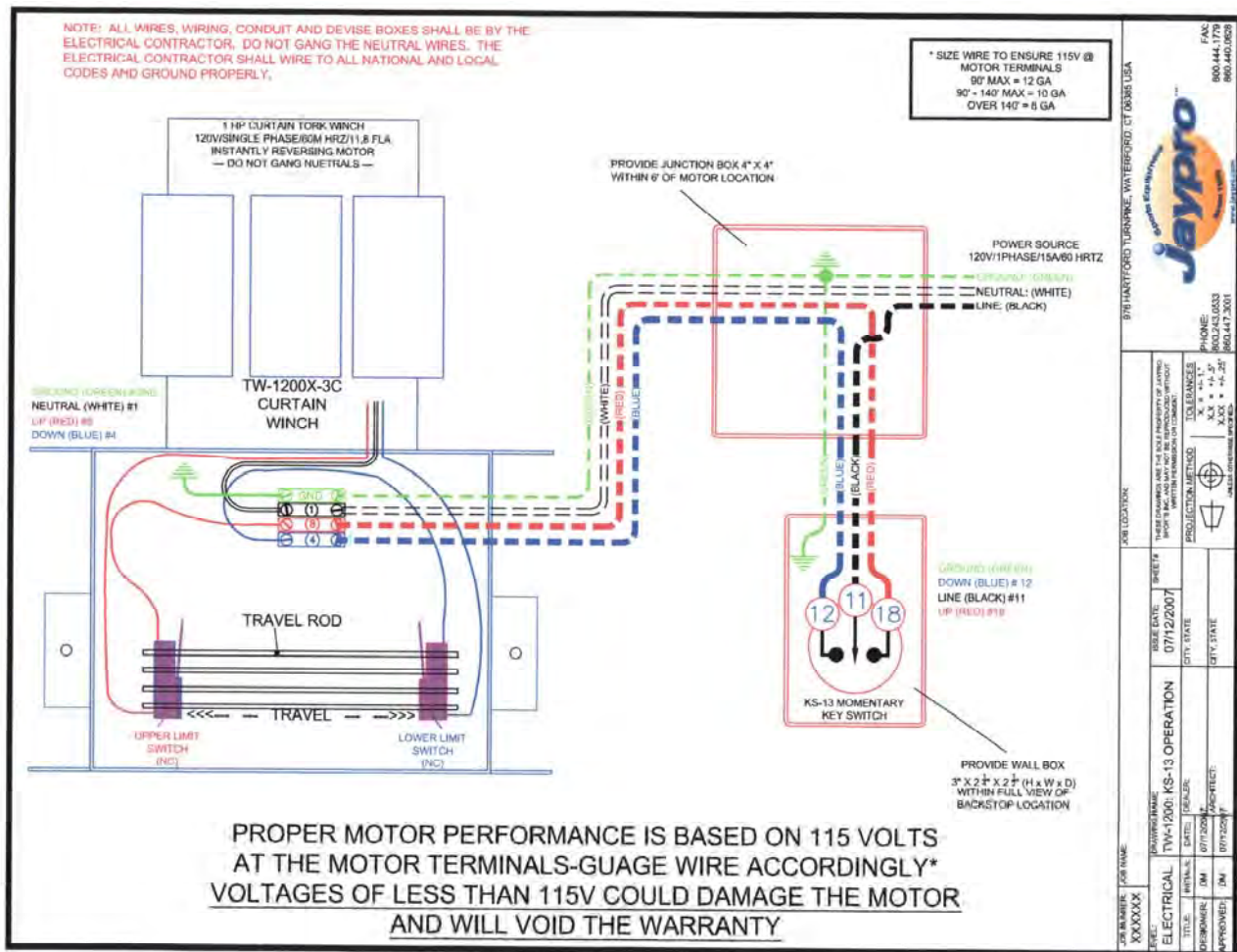
Clamp the two cables together at aprox 24" up the main hoist cable.





## ***ELECTRIFY THE WINCH.***

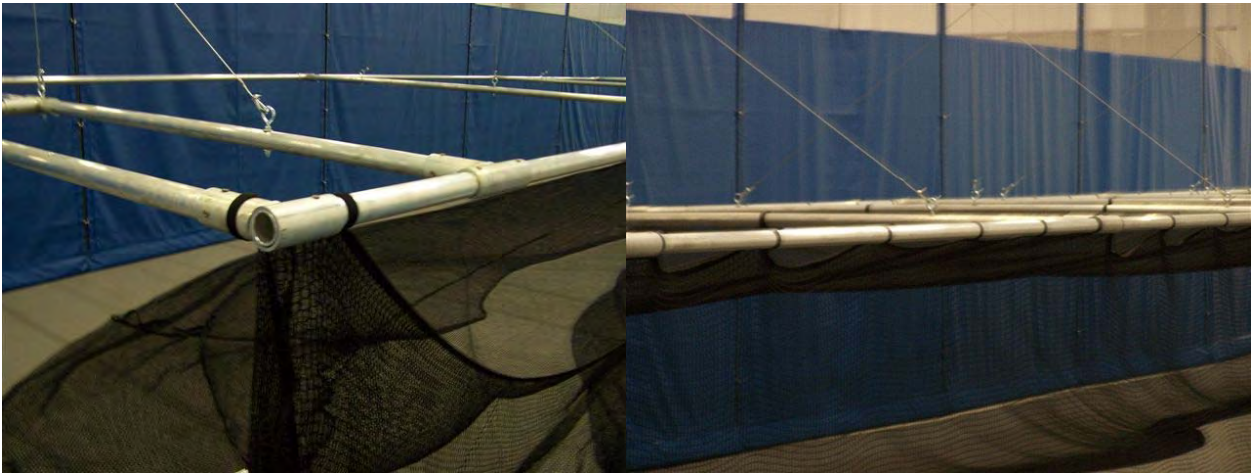
1. A licensed electrician should perform the final electrical hook ups.



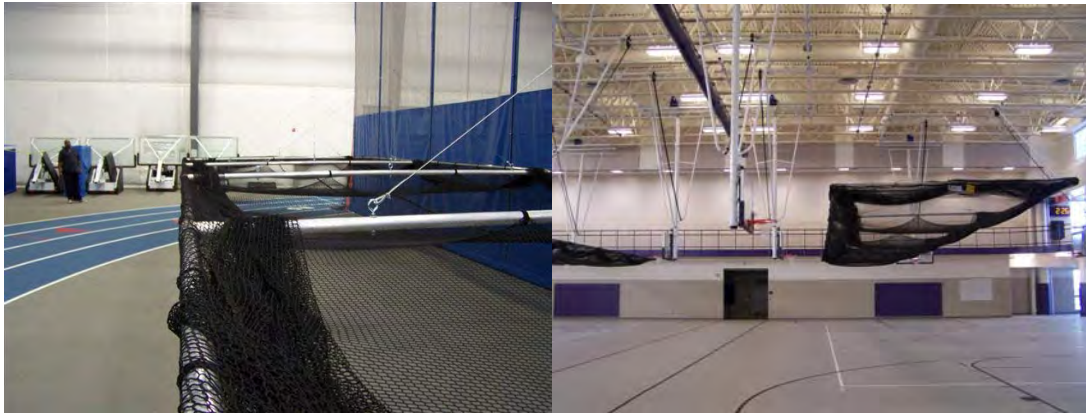
## ***HOIST THE FRAME OFF THE GROUND TO APROX 4 1/2- 5' AFF***

## ***ATTACH THE NET TO THE FRAME WITH THE VELCRO.***

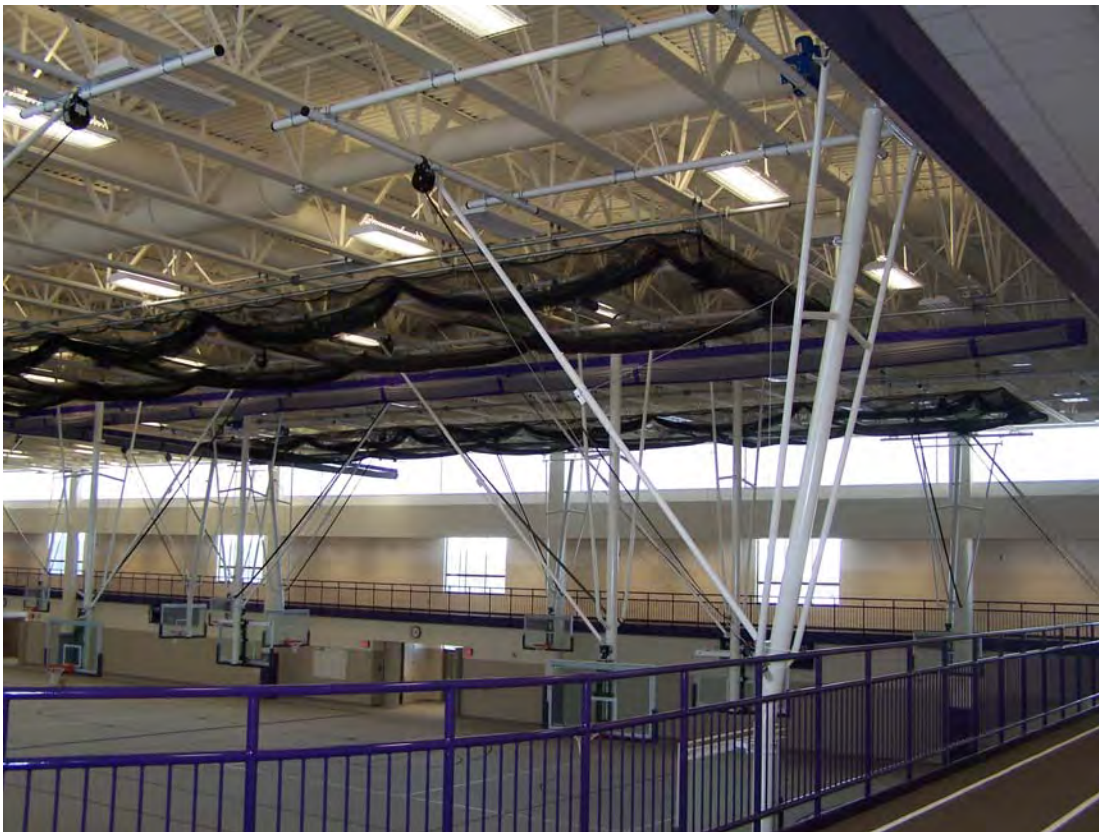
1. Two sided hook and loop tape is provided in a roll.
2. Cut the tape into 9" strips to secure the net to the frame.
3. The 9" tape section is wrapped around the frame pipe and through the net and secured to itself.
4. Strips should be placed 18-24" center to center along the sides and cross members of the cage frame.



***ROLL THE NET ONTO THE TOP OF THE FRAME.***



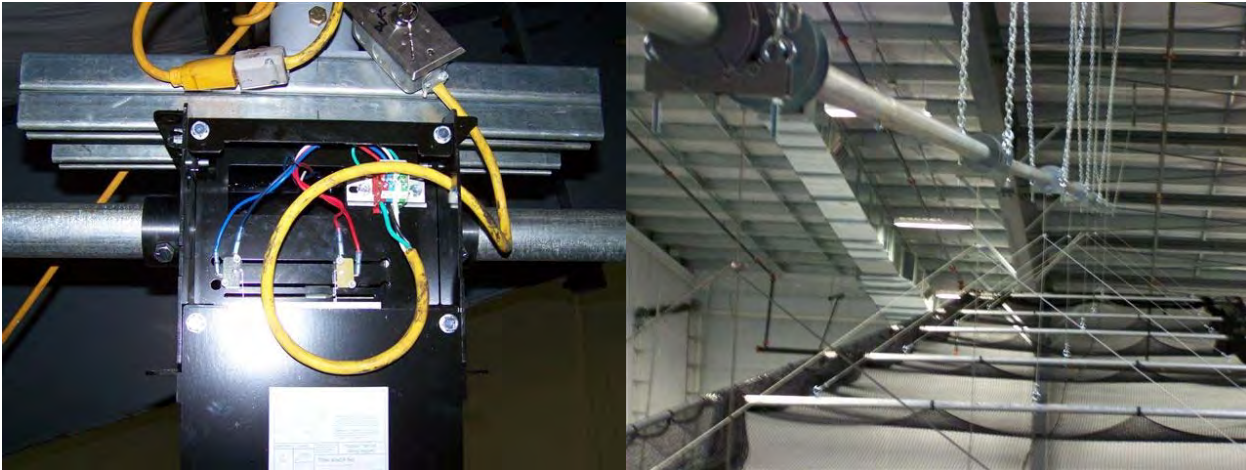
***HOIST THE FRAME AND NET TO THE CEILING***





***SET THE UPPER LIMIT SWITCH OF THE WINCH.***

1. It is recommended that the upper limit be set with a margin of safety. The highest cable clamp on the hoist cable should come to rest between 8 and 12” below the drive pipe.



***LOWER THE FRAME AND ESTABLISH AN ADJUSTED LOWER LIMIT APROX 3’ AFF***



***UNROLL THE NET FROM THE TOP OF THE FRAME TO HANG FREELY***

***RAISE THE FRAME TO 10’ AFF***

1. THIS SHOULD LEAVE APROX 1’ OF NET ON THE GROUND AND IS DESIREABLE ***IF SO EQUIPPED. INSTALL A TARGET TO THE BATTERS END OF THE NET.***

1. REMOVE TARGET PRIOR TO HOISTING

# --- Jaypro Batting Cage System ---

## Installation Record

**Installer** - please provide the following information and fax a copy to (860) 440-0628:

Installer Name:	_____
Phone #:	_____
Date:	_____

G. C. Name:	_____
Phone #:	_____

Facility Name: (in which this Batting Cage system was installed)
_____
Address: _____
_____
_____
Contact Name: (Person who received keys for system or other facility representative)
_____
Phone #: _____
_____

Call Jaypro Sports Equipment at 1-800-243-0533 during regular business hours for technical support.

[www.jaypro.com](http://www.jaypro.com)