

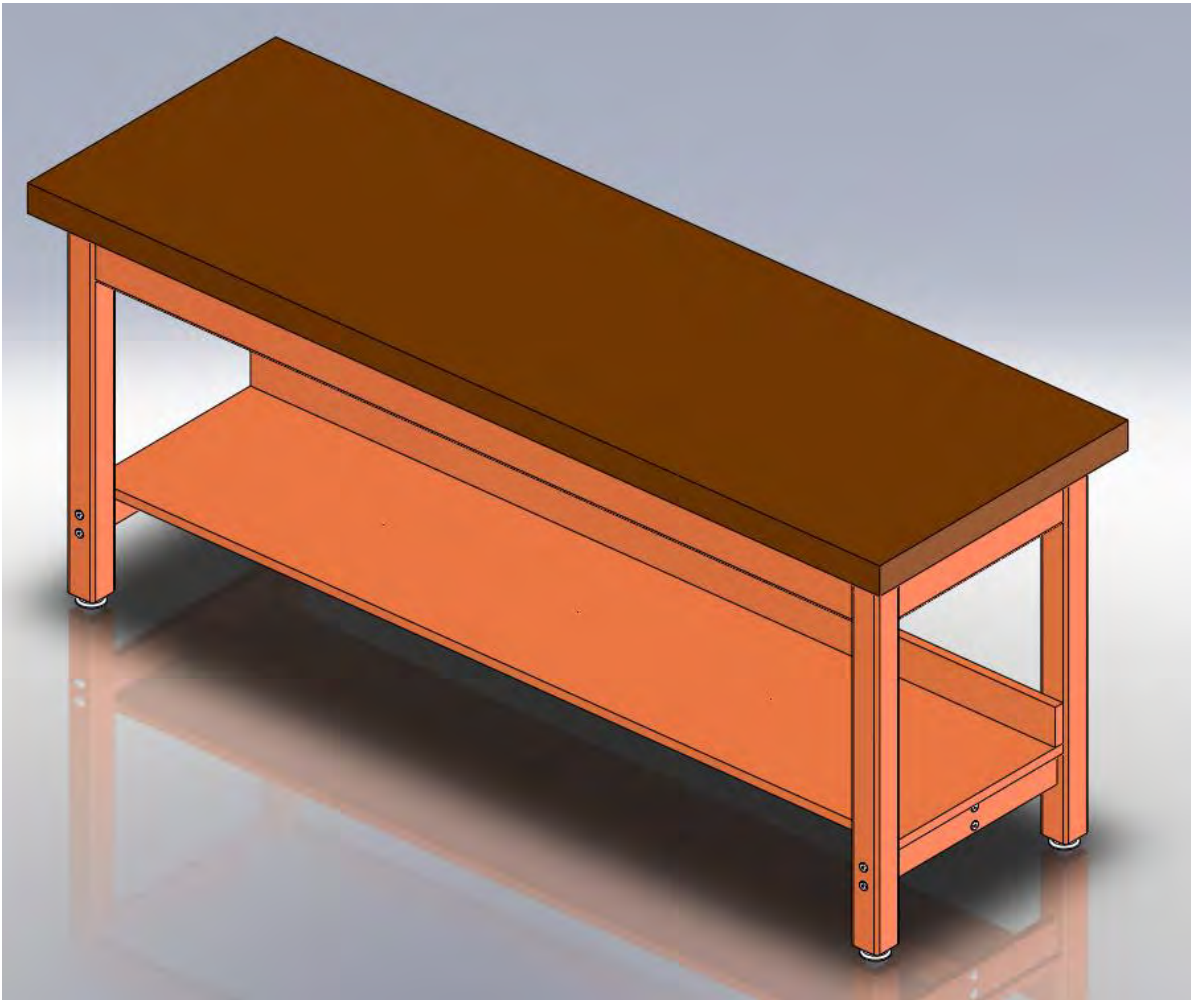

ASSEMBLY INSTRUCTIONS

A32 WORKBENCHS ASSEMBLY INSTRUCTIONS



***Model views may not represent exact model purchased**

TABLE OF CONTENTS

ASSEMBLY COMPONENTS	3
APRON TO LEG ATTACHMENT	4
LEG ASSEMBLY	5
LEG BRACES & STRETCHERS	6

ASSEMBLY COMPONENTS

ITEMS INCLUDED	PART #		PART#
1-LEG KIT, TABLE		1-APRON ASSY, TABLE	
1-TOP, TABLE		HARDWARE BOX	
1--SCREW, #12.00X1 1/2	100062	8-SCREW, 7MMX90MM	227578
8-SCREW, 7MMX50MM,	228564		
6- SCREWS, #8.00X1.5 FSQ	100066		

REV	DESCRIPTION	DATE	NAM
---	Original Created	6-10-09	NAM

Assembly Instructions

Items not included but needed for assembly:

1. ½” wrench

Instructions:

1. Lay the table on the floor with the apron side up. (Be sure to lay the table on a clean surface so you don't damage the tabletop.)

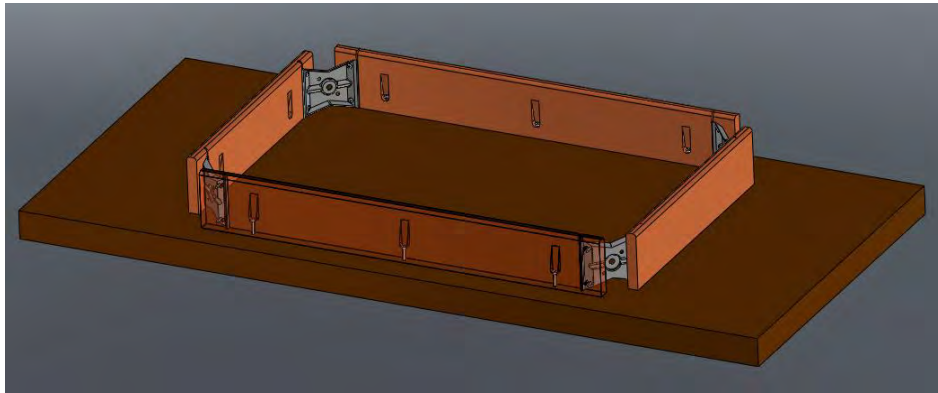

2. Take each of the table legs and insert the stud bolt through the hole in the steel corner brace.

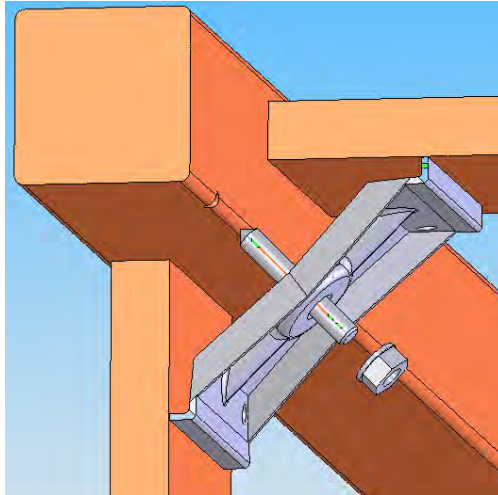

3. Apply a lock washer and a 5/16” nut onto each stud bolt. Tighten each nut using a minimum of 12 foot-pounds but not exceeding 17 foot-pounds of torque.

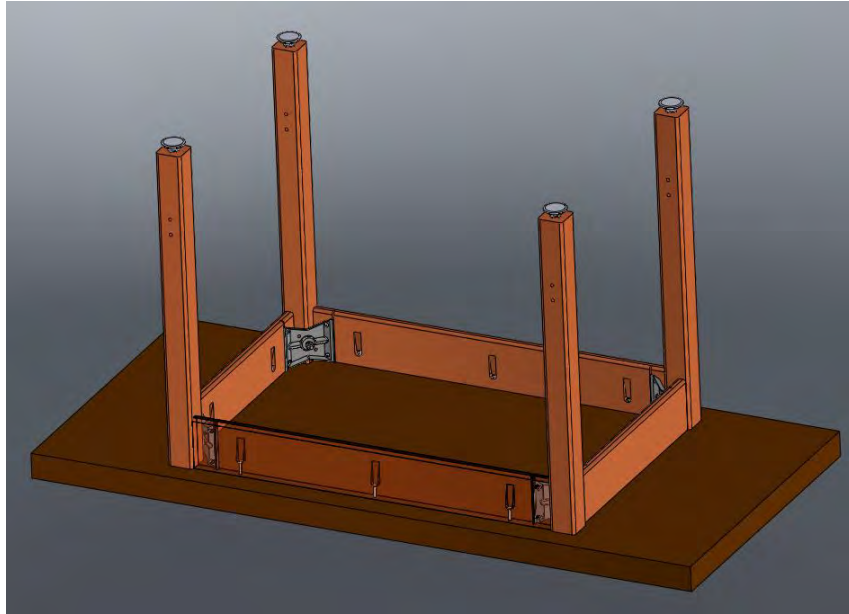

4. Slide leg boots onto the legs with the flared end toward the bottom of the leg.
5. Screw leg levelers into t-nut in the bottom of the leg.

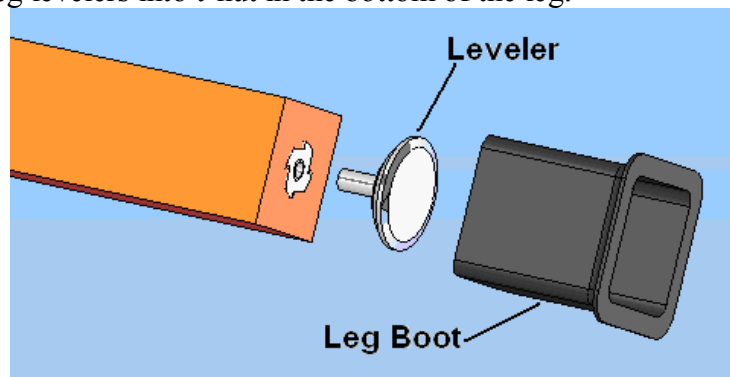

6. **NOTE: TABLES WITH LEG BRACES AND STRETCHERS SEE FIGURE 8A.**

FIGURE 8A

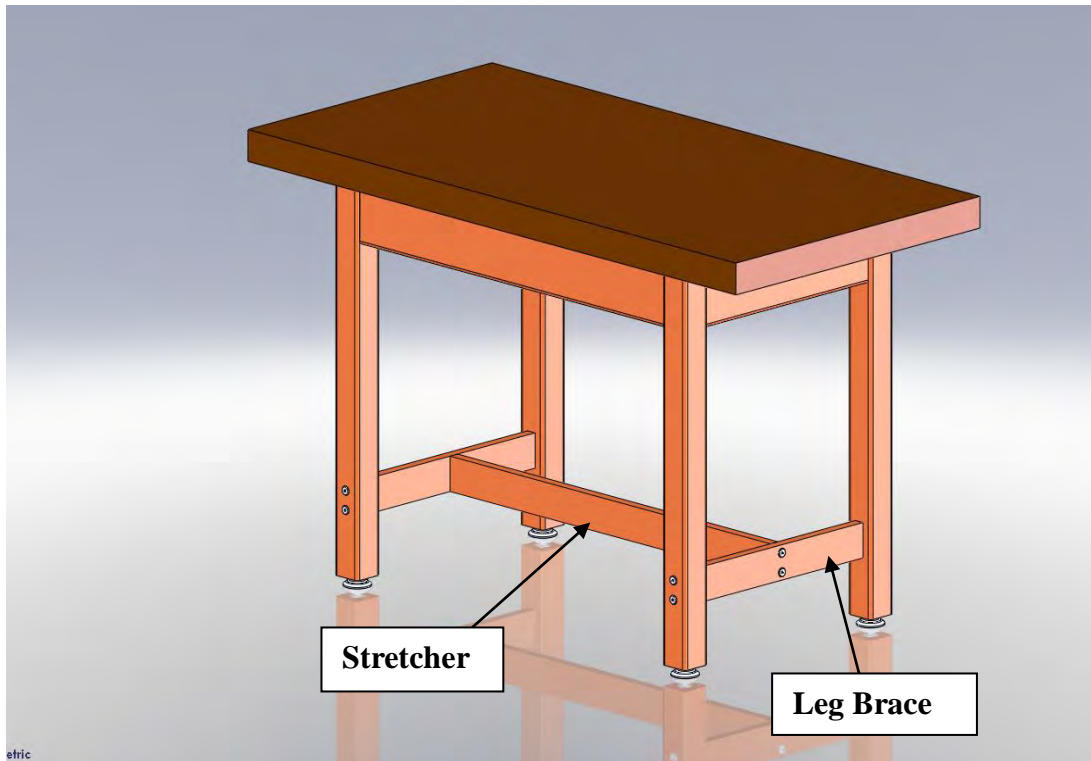

7. Attach leg braces with: (SCREW,7MMX90MM,CONN,ALLENHEAD,BLACK)
Provided
8. Attach stretcher with: (SCREW,7MMX50MM,CONN,ALLENHEAD,BLACK)
Provided
9. Attach shelf using SCREWS,#8.00X1.5 FSQ SMS TYPE 17 (100066)
10. Turn the table over so the top is up. Set your table in place and adjust the leg levelers to level the table.
11. Slide the leg boot down to the floor.