

1 Locate and Drill holes for Z-Hangers.

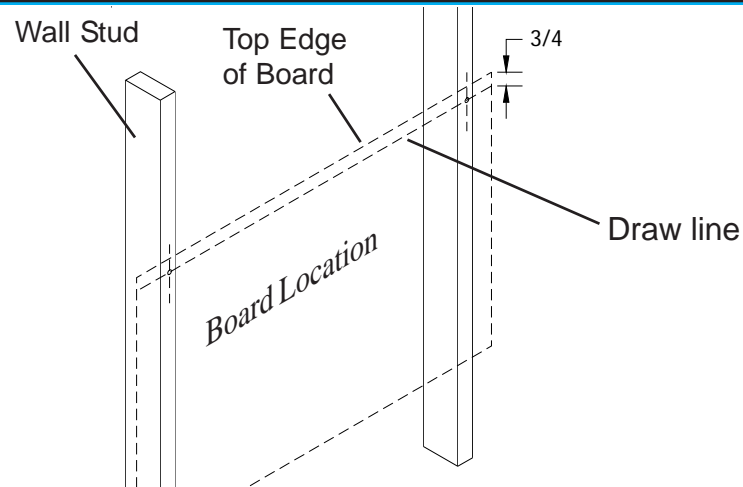

Determine board location. Measure from floor to the top edge of board. Mark with pencil line the corner location. Measure down from top edge of board 3/4", and draw line as shown. Locate stud near each end of board and drill pilot hole along line using 1/16" drill bit.

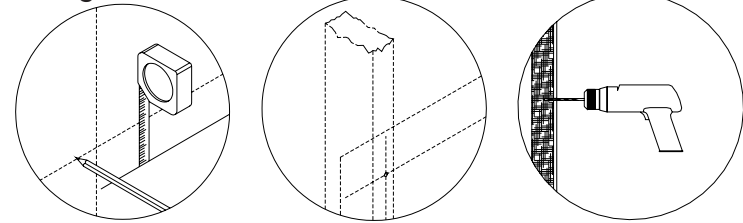

2 Attach Z-Hangers for mounting.

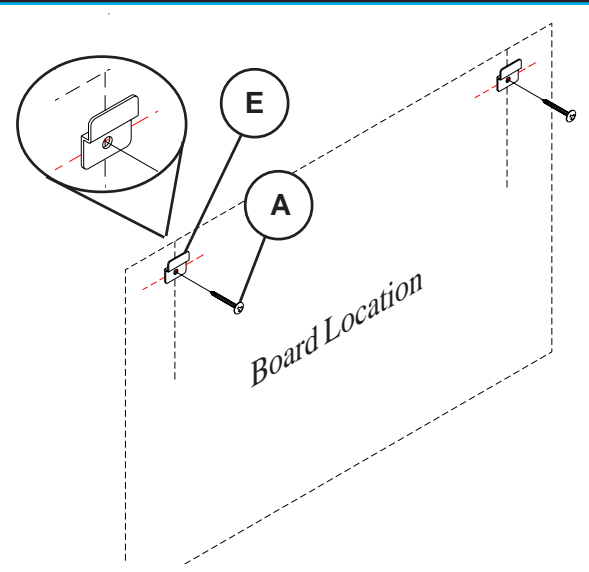

Attach 2 Z-Hangers (E) using 2 Long Screws (A) as shown.

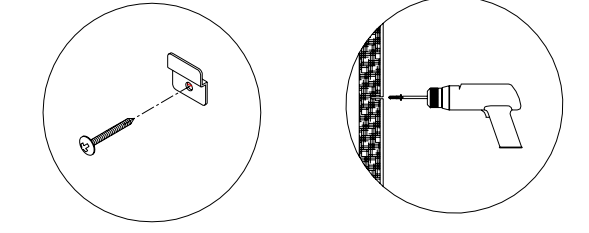

3 Hang board and mark bottom

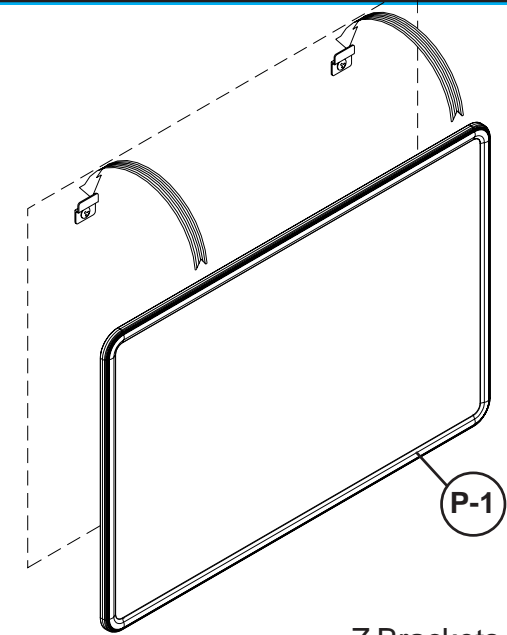

Lift, Tilt, and Slide Board down over the Z-Hangers. Z-Hangers should catch in the top trim on the back of the board. Draw line along bottom edge of board.

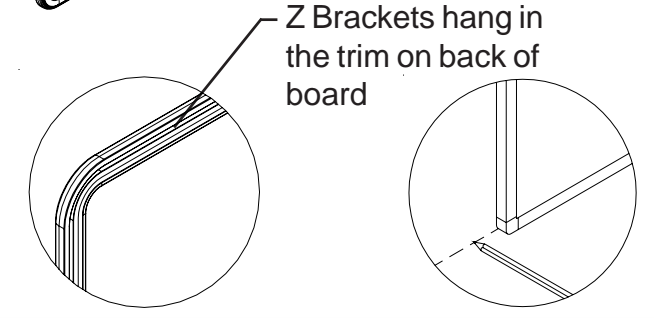

4 Remove board and drill

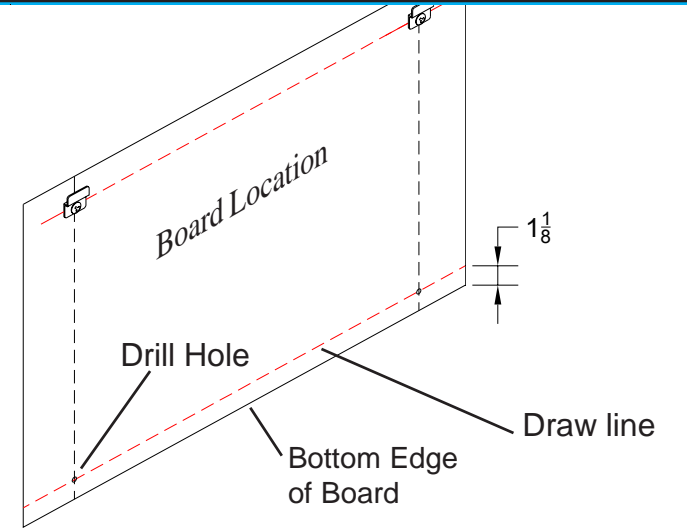

Lift and remove board from the Z-Hangers. Measure up from bottom line of board 1-1/8", and draw line as shown. Locate stud near each end of board and drill pilot hole along line using 1/16" drill bit.

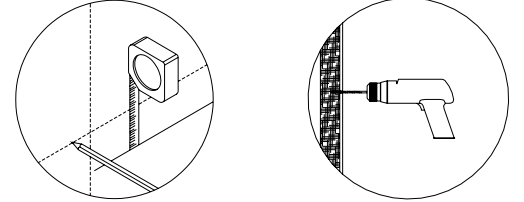

5 Attach Lower Brackets and Hang board

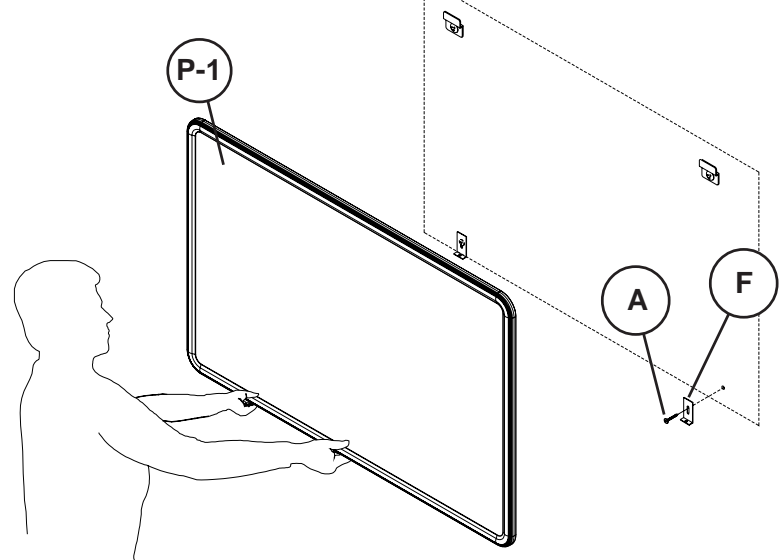

Secure 2 bottom brackets (F) to the wall using 2 long screws (A) as shown. Hang board on the Z-Hangers (E).

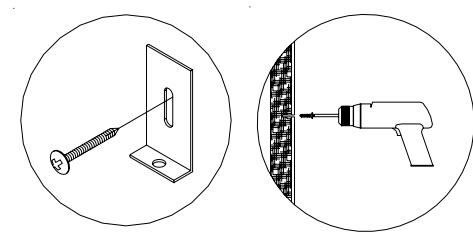

6 Secure Board & Attach Q-Tray

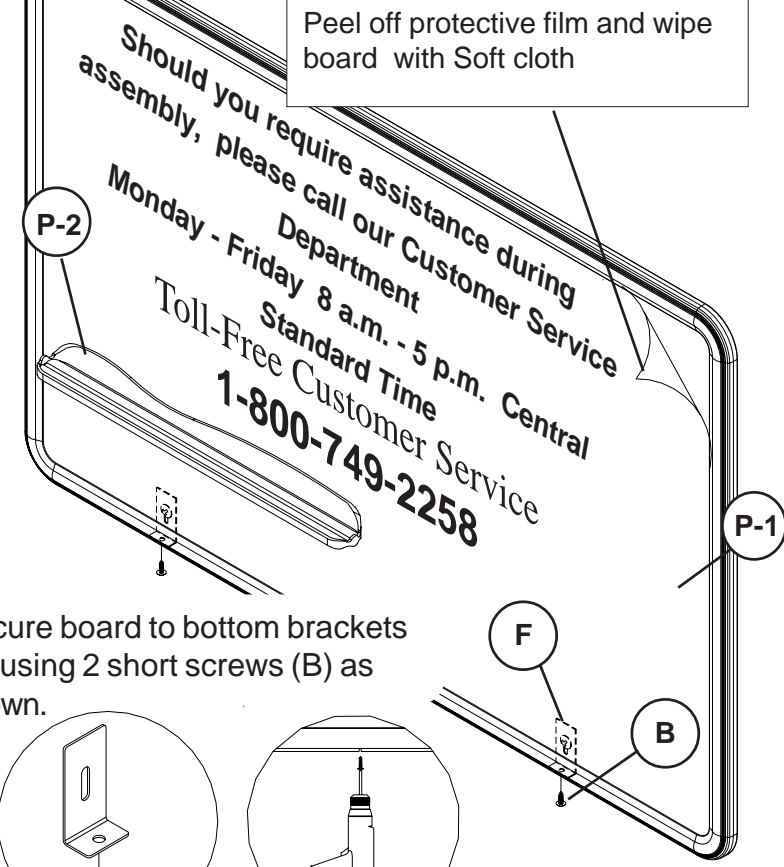

Secure board to bottom brackets (F) using 2 short screws (B) as shown.

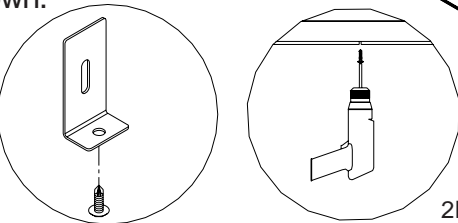

Parts List		
P1	Board	1 EA
P2	Q-Tray	1 EA

Hardware List		
A	Long Screw	8 EA
B	Short Screw	4 EA
C	Screw Anchor - Concrete	8 EA
D	Screw Anchor - Drywall	8 EA
E	Z Hanging Bracket	4 EA
F	Bottom Bracket	4 EA



2H2PD,PG,PH
4x4,4x6,4x8 Porcelain
Presidential Trim

