



Model No. NEX006XP



COLLABORATIVE

INTERACTIVE

VERSATILE



Interact and View –

Nexus X-Pegs are a flexible, low-profile display system for Tablet markerboards that accommodate a variety of wall-mounting options.



nexus™
by Ghent

simplifying small group communication



Collaborative

Fosters open team communication by visually displaying individual Tablets in a group setting

Interactive

Easy to switch Tablet from table workspace usage to meeting room wall-mounted display and back

Versatile

Allows for multiple hanging options for display and usage of Nexus Tablets

Key Features

- Low-profile wall visibility – requires only a single pair of X-Pegs per Tablet markerboard
- Flexible mounting options – X-Peg pairs can be mounted in a single row for presenting a line of multiple Tablets or in multiple rows for upper level image display and lower level writing
- Easy to hang – attaches to wall with single fastener
- Simple to use – Tablet corner designed with X-Peg sized opening for intuitive connection and fit
- Backed by a Ghent 1-year guarantee

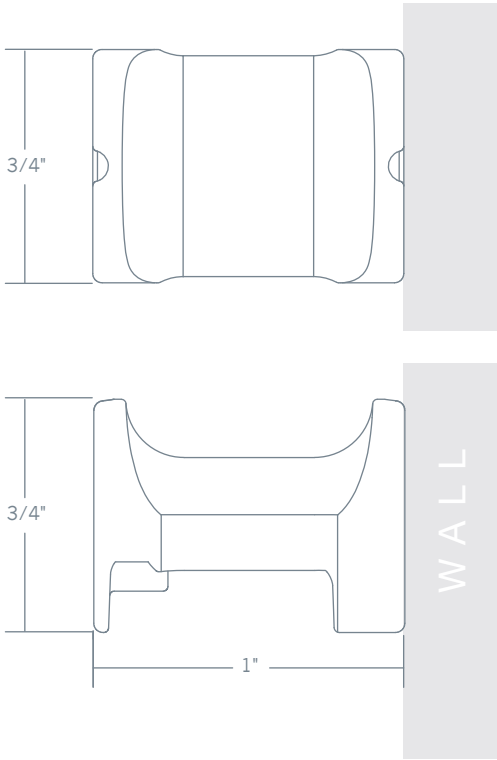
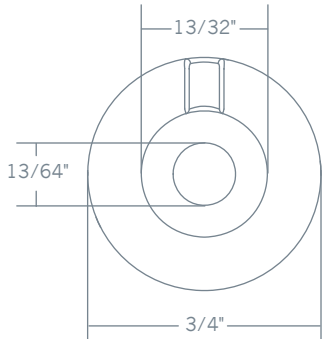

Find out more
NexusByGhent.com

Specifications		Model No.
Width	3/4" (1.905 cm)	NEX006XP
Depth	1" (2.54 cm)	

GHENT

Ghent Manufacturing, Inc.
 2999 Henkle Drive
 Lebanon, Ohio 45036
 T 800-543-0550
 P 513-932-3445
 F 513-932-9252
ghent.com

