



Model No. NEX106TM



INTERACTIVE

MOBILE

COLLABORATIVE

**Think and Contribute –**

the Nexus Tablet is a lightweight and portable solution that provides a markerboard workspace for use wherever it is needed.



**nexus™**  
by Ghent

simplifying small group communication



<p><b>Interactive</b> Connects with the mobile Nexus products or on the wall using X-Pegs™</p>	<p><b>Mobile</b> Allows handy transport to go and be used wherever a markerboard is needed</p>	<p><b>Collaborative</b> Conducive for breakout sessions and for capturing free-flow idea generation</p>
--	--	---

**Key Features**

- Compact – simple to move from room to room for use and to pack away for storage
- Lightweight (approximately 3 lbs) – conducive for breakout sessions away from main presentation area
- Self-contained – uses a combination holder for marker pen and eraser that attaches between the handles and aluminum framing
- Environmentally friendly – more durable, reusable and greener solution than traditional chart pads
- Right-sized – roomy 28" x 28" double-sided, high-pressure laminate markerboard workspace for personal use or group interaction
- Backed by a Ghent 1-year guarantee

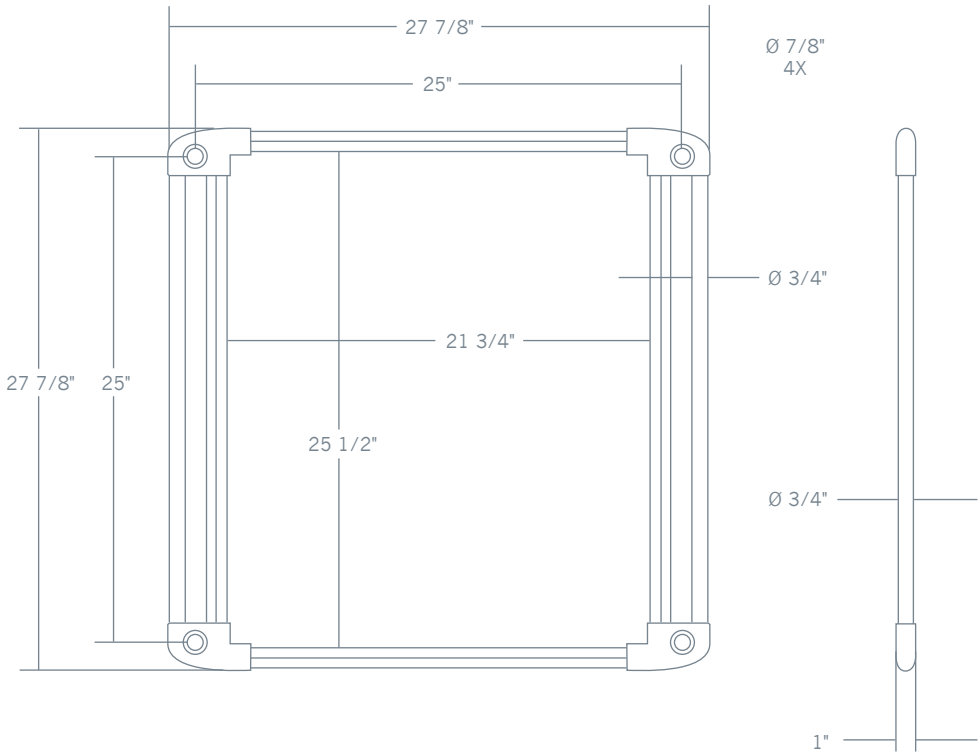

Find out more  
NexusByGhent.com

Specifications		Model No.
Dimensions	27-7/8" (70.8 cm) x 27-7/8" (70.8 cm) x 3/4" (1.9 cm)	NEX106™
Writing Space	21-3/4" (55.2 cm) x 25-1/2" (64.8 cm)	
Weight	3 lbs	

**GHENT**  
Ghent Manufacturing, Inc.  
2999 Henkle Drive  
Lebanon, Ohio 45036  
T 800-543-0550  
P 513-932-3445  
F 513-932-9252  
ghent.com

